

Installation, maintenance, assembly and operating manual for back pressure regulator type BPV



BA-BPV-01-EN

Version: 01.2018

Content

1	General	3
1.1	Customer service and procedure when servicing	3
1.2	About this manual	3
1.3	Applicability of this operating manual	4
1.3.1	Applicable documents	4
1.4	Subject to change	4
1.5	Warranty/guarantee	4
2	Explanation of symbols and safety instructions	5
2.1	Explanation of symbols	5
2.2	Notes on dangers and warnings	6
2.3	Safety instructions	7
3	Packing	8
4	Transport and storage	9
5	Description and technical data	10
5.1	Intended Use	10
5.2	Design of the back pressure regulator type BPV	10
5.3	Functioning of the back pressure regulator type BPV	13
5.4	General notes regarding operation of the valve	15
5.5	Identification of the valve	15
6	Installation of the valve in the plant	16
6.1	Please observe before the installation in the pipeline!	16
6.2	Installation of the valve	20
7	Pickling and flushing	20
8	Removal of the valve	20
9	Disassembly and assembly of the valve	21
9.1	General assembly and disassembly information	21
9.2	Disassembly and inspection of the valve	22
9.3	Assembling the valve	23
10	Commissioning	24
11	Maintenance	25
12	Inspections and inspection schedules	26
12.1	Inspections	26
12.2	Inspection schedules	26
13	Causes and remedies in the event of failures	27
Appendix		30

A.1 Form for the malfunction30

1 General

1.1 Customer service and procedure when servicing

Please contact for additional information:

SCHROEDAHL GmbH

Alte Schoenenbacher Str. 4
51580 Reichshof-Mittelagger

Tel.: +49-2265-9927-0
Fax: +49-2265-9927-927

E-mail: schroedahl@circor.com
Internet: <http://www.schroedahl.de>

In the event of malfunctions, please fill out the form attached in the Annex and send to the following contact person of SCHROEDAHL:

SCHROEDAHL GmbH

-After Sales Service-
Alte Schoenenbacher Str. 4
51580 Reichshof-Mittelagger

Tel.: +49-2265-9927-0
Fax: +49-2265-9927-927

E-mail: schroedahl_service@circor.com
Internet: <http://www.schroedahl.de>



INFORMATION

Please refer to the marking on the housing for information on the technical data of the back pressure regulator. (see chapter 5.5 Marking of the valve).

1.2 About this manual

General:

This manual applies to installation, maintenance, assembly and operation, unless otherwise agreed. Please refer to the conditions agreed in the purchase order in this connection.

The manual contains basic instructions to be followed for transportation, storage, assembly, commissioning, operation, maintenance and repair. This manual is therefore mandatorily to be read before transportation, storage, installation, commissioning, operation, maintenance and repair by the qualified personnel as well as the assigned operator and must be available at the place of operation.

Also please note in particular the rules and the operating instructions given together with the danger, warning and information symbols. Your non-compliance can lead to damage to the valve as well as slight and heavy injury to persons. If any questions arise after reading through the manual, then please contact the manufacturer or the associated local Sales personnel.

1.3 Applicability of this operating manual

This manual applies to valves of the series given on the cover sheet. The conformity of the above type designations with the marking of the valve should be ensured before beginning any action and spare part order.

The rules, guidelines and notes given in this operating manual apply to delivery to the EU. Operators outside the EC, in their sole responsibility, must consider the listed rules as a basis for safe handling and assess their implementation against the rules applicable for the erection site.

1.3.1 Applicable documents

This operating manual always includes the standard documents of the valve, such as:

- Data sheet
- Sectional drawing
- Parts list
- Dimension sheet

These order-related documents are supplied along with each purchase order.

1.4 Subject to change

The rules, guidelines and notes mentioned in this operating manual correspond to the status of information at the time of the order and are not subject to amendment service. The operator is responsible and obliged to apply them in their latest and valid versions. In principle, the product suitability for a new version cannot be hereby derived.

1.5 Warranty/guarantee



The scope and period of a warranty have been specified especially in the "General Terms and Conditions of Sale" or in the contract. The latest version, applicable at the time of delivery, is valid. The details given in this manual are used only to specify the products, and no properties are assured.

Unless special conditions have been agreed upon in the order, our warranty is for 1 year, but limited to 24 months after shipment outside EU.

The manufacturer accepts no liability for, or the warranty excludes, damages or breakdowns due to:

- Non-compliance with this installation, maintenance, assembly and operating manual.
- Damages that have obviously occurred during commissioning due to pollution or unusual operating manner.
- The pressure reduction units and seals subject to wear.
- Unsuitable or improper application as well as during unintended use.
- Faulty assembly, maintenance, incorrect commissioning or to improper operation.
- System-related vibrations of the plant that can arise under certain conditions during pump switching operations, quick shut-off etc.
- Improper operating manner (deviating from the operating data in the data sheet).
- Incorrect or careless handling of the valve.
- Damages caused by components that do not belong to the valve itself.
- Contaminations in the medium (if different from the planned operating conditions).
- Use by inadequately qualified assembly, operating and/or maintenance personnel.
- Unauthorised reworks.
- Changes or reworks on the valve, which are improper or carried out without the prior approval of the manufacturer.

- Use of unapproved spare parts and accessories.

 NOTE	The trim parts and seals of the valve are considered as wear parts.
 NOTE	Our warranty covers only the return and the replacement of faulty material or products.

2 Explanation of symbols and safety instructions





This installation, maintenance, assembly and operating manual specifically focuses on dangers, risks and safety-relevant details by means of an emphatic display.

Notes on dangers and warnings in the text describe rules of conduct, whose non-compliance can lead to serious injuries or death of users or third parties or to property damage of the plant or the environment. They should be followed without fail and marked with a warning triangle.







However, the observance of notes and details is equally indispensable to avoid breakdowns that can directly or indirectly cause damages to personnel or property.

The following dangers, warnings and notes do not take into account any additional regional, local or company-specific safety regulations and it is the responsibility of the operator himself to add them.

2.1 Explanation of symbols

 DANGER	Death, serious bodily injury or substantial property damage will occur, if the relevant precautions are not taken.
 WARNING	There is a threat of property damages or harmful environmental influences in the event of non-compliance with warning.
 NOTE	Is a reference to a possible advantage in the case of compliance with the recommendation.
 INFORMATION	Gives useful tips and suggestions.

2.2 Notes on dangers and warnings

 DANGER	<p>The valve is under pressure and usually at high temperature during operation.</p> <p>Non-compliance can result in death, serious bodily injuries or substantial property damages.</p>
 DANGER	<p>The valve can also still contain the medium in a pressure-free condition. Protection measures should be taken from the safety data sheets of the manufacturer of the medium.</p> <p>Warning: Serious injuries possible!</p> <p>Suitable protective clothing is required for assembly and maintenance work.</p>
 DANGER	<p>As for their danger potential, valves should be treated equivalent to pressure containers. Therefore, the standards, guidelines, accident-prevention regulations, reliability regulation, plant-specific safety regulations corresponding to planning, installation, operation, testing, assembly and maintenance, the relevant site regulations and the technical documents concerning the valve must be followed. Amended requirements or additions are also applicable at the time of installation and must be complied with.</p>
 DANGER	<p>The valves should only be operated within their limits of design and layout. These limits should be taken from the marking on the valve. They should be operated only within their specified performance limits (see technical data). No modifications must be carried out on the valve without the consent or approval of the manufacturer. In particular, the values for the pressure rating, the design pressure, the design temperature and test pressure must not be exceeded, since it may otherwise lead to overloading of the valve.</p> <p>Only those media must be used, against which the materials are resistant and whose application has been planned for this. Dirty media or applications of the valve outside the specified values can lead to component damages.</p>
 DANGER	<p>Assembly and maintenance work can only be carried out when the plant has been shut off and the valve is without pressure and has cooled down. Please also follow the plant-specific guidelines.</p>
 WARNING	<p>Do not mount or operate the valve and do not carry out any adjustments on it, if the valve or the supply lines have been damaged.</p>
 WARNING	<p>The plant should be commissioned again only after completion of the installation and maintenance work.</p>

2.3 Safety instructions

<p>! NOTE</p>	<p>Prerequisite for the installation, operation and maintenance of this valve is the engagement of qualified personnel. It concerns the personnel who are familiar with the installation, commissioning, operation and maintenance of the valve because of their technical training and experience. During the guarantee period, these works must be carried out by SCHROEDAHL personnel or by the plant personnel with a report to Schroedahl. The operator has the responsibility for it and monitoring of personnel must be done by him. If the operator does not possess the required specialised knowledge, then a specialist company should be engaged. Any person entrusted with one of the measures described in this operating manual must have read and understood this manual.</p>
<p>! NOTE</p>	<p>Use appropriate tools and devices for installation, maintenance and assembly. Use of spare parts should correspond to the parts list given in the order. These should be procured exclusively from SCHROEDAHL or from our authorised dealers. After completion of the installation, maintenance or repair, test the correct function of the valve and check that there is no leakage in the connecting lines.</p>
<p>! NOTE</p>	<p>The valve should be regularly subjected to a safety check in accordance with the company-specific safety regulations and statutory requirements. In this case, especially the pressurised components and connecting elements should be checked for wear and corrosion.</p>
<p>! NOTE</p>	<p>If the valve uses fluids that are harmful to the people or the environment, then the operator should fix a warning note very close to the valve.</p>
<p>! NOTE</p>	<p>Use of the valve other than as intended is not permitted.</p>
<p>! NOTE</p>	<p>The valves should only be operated within their limits of design and layout.</p>
<p>! NOTE</p>	<p>No modifications must be carried out on the valve without the consent or approval of the manufacturer.</p>
<p>! NOTE</p>	<p>For installation, operation, maintenance and assembly of the valve, the currently applicable standards, guidelines, accident-prevention regulations, reliability regulation, plant-specific safety regulations, site regulations and technical documents should be followed.</p>

3 Packing



- The valves should be sent from the works in a dry and good condition. The port holes should be closed with plastic caps or such like.
- Depending on the size on a pallet, the valve is shipped in a skid-carton or a wooden crate. The warnings on the packing must be followed. Special packing and conservation for larger periods of time must be indicated separately in the purchase order.
- Transportation, unloading and lifting of the delivery unit must be carried out with the required caution as well as using tools that correspond to the weight and the dimensions.
- Check the packaging for integrity at the time of delivery.
- Check the scope of supply for completeness.
- Check whether the identification of the valve on the housing (see Chapter 5.8 Identification of the valve) corresponds to your order.
- In the case of damage, incomplete or incorrect delivery, contact your forwarding agent, the person engaged for transportation or us.



NOTE

We accept no liability for damages resulting from improper transportation, loading or unloading.

4 Transport and storage



 WARNING	Improper transportation can cause property damages to a significant extent.
 WARNING	Appropriate transportation and lifting devices must be used. For weights, see dimension sheet.
 WARNING	The valve should be protected against external force (impact, shock, vibration, etc.).

During transportation and intermediate storage, the following points should be respected.

- The valve should be stored in a dry, clean, well-ventilated and safe place until the assembly.
- The transportation and storage temperature should be between -10 °C and +50 °C.
When stored below -10 °C, our winter inerting regulations must be observed.
- Any damage to the corrosion protection (painting) should be immediately rectified.
- If the storage is to be done for a longer period of time (longer than 6 months), special packing and conservation must be specially planned by you.
- Keep the valve using the factory protective measures (foils, boxes, pallets, etc.)
- The flange plugs must be removed only at the place of operation.
- Installation position, dimensions and weight of the valve should be documented in the dimension sheet and complied with.
- In the case of valves with a weight of over 25 kg, it is necessary to ensure that mounting lugs and lifting tools are available above the mounting location to a sufficient height.

5 Description and technical data

5.1 Intended Use

 <p>DANGER</p>	<p>The valves should only be operated within their limits of design and layout. These limits should be taken from the nameplate. They should be operated only within their specified performance limits (see technical data). In particular, the values for the pressure rating, the design pressure, the design temperature and test pressure must not be exceeded, since it may otherwise lead to overloading of the valve.</p> <p>Only those media must be used, against which the materials are resistant. Dirty media or applications of the valve outside the specified values can lead to component damages.</p>
 <p>WARNING</p>	<p>In the piping system, the usual flow velocities for continuous operation should not be exceeded. Operating conditions such as vibration, pressure surges, cavitation and ingredients of solid materials (in particular abrasive materials) in the medium must be clarified with the manufacturer in advance.</p>

5.2 Design of the back pressure regulator type BPV

The back pressure regulator, also known as back pressure valve, (BPV), is available in the Z-version (intermediate flange version) and K-version (version with flanges). The back pressure regulator consists of a body (item 201) and a connecting flange (item 204.2) which are connected to each other with two grub screws (item 219). The O-ring (item 203) provides the seal between housing and connecting flange. The internal parts of the back pressure valve consist of a control bush (item 204), an orifice plate (item 204.1), a bush (item 206), and a spring (item 237). The internal parts also include two O-rings (item 207 and item 208), as well as two guide rings (item 207.1 and item 208.1).

The standard housing materials are carbon steel, stainless steel or duplex steel.

Selection of the housing material according to design pressure, design temperature and medium. The standard internals are made of stainless steel with a minimum chrome content of 13%. Other materials for housing and internals upon request. Selection of the seal material is done according to medium and temperature conditions.

The valves of the type BPV are available in standard sizes from DN 25 (1") up to DN 200 (8") and pressure ratings according to EN of PN 16 to PN 400 or ASME class 150 to class 2500. Special sizes and special pressure ratings are available on request.

Flanges conform to EN or ASME standards. Flanges in accordance with other standards and regulations (e.g. ISO, BS, JIS, NF) as well as connections with welding ends are also possible on request.

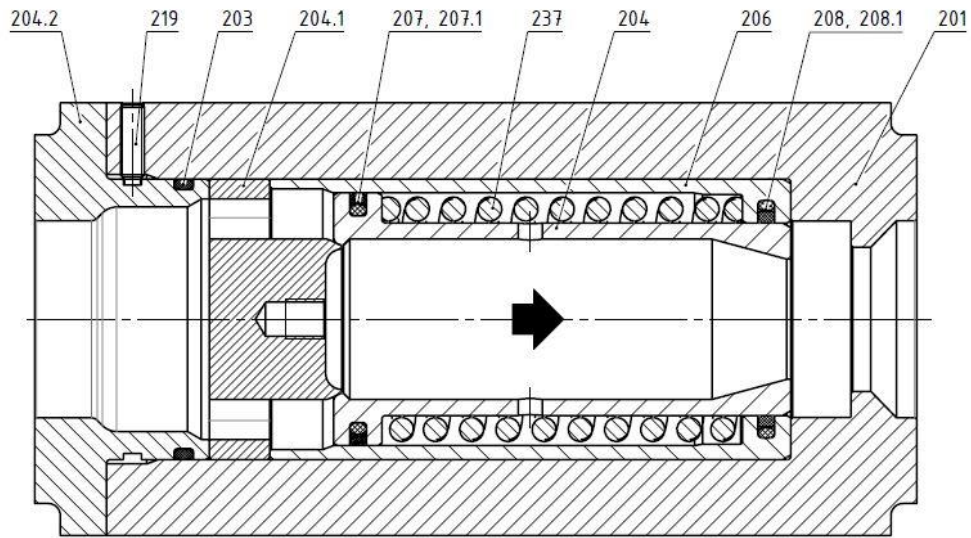

Figure 1 Sectional drawing of back pressure regulator BPV (Z version)

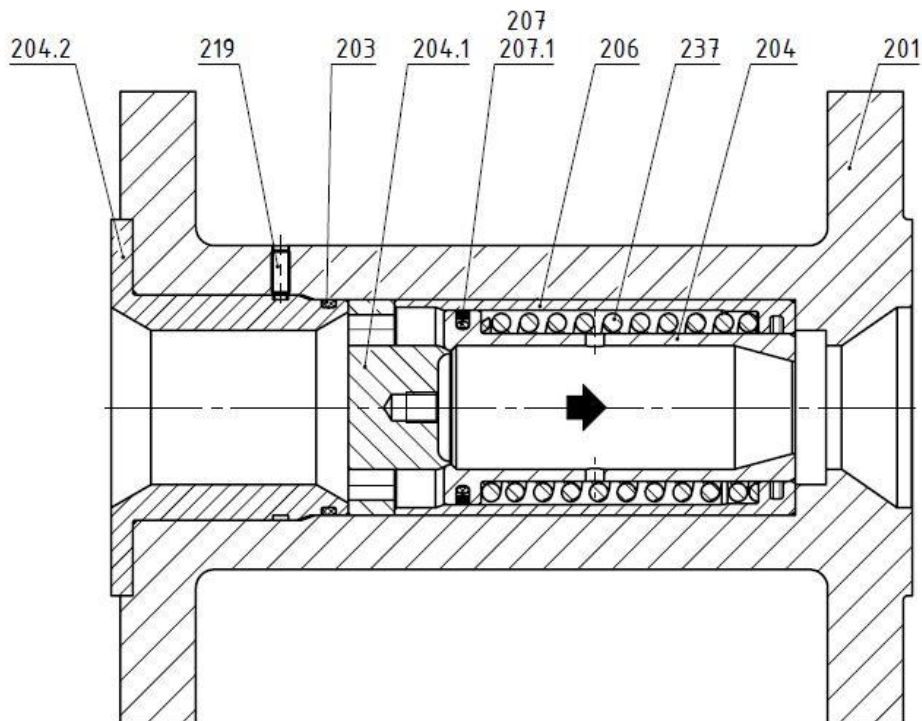

Figure 2 Sectional drawing of back pressure regulator BPV (K version)

Housing	
Item	Description
201	Housing
203	O-ring
204	Control bush
204.1	Orifice Plate
204.2	Connecting flange
206	Bushing
207	O-ring
207.1	Guiding ring
208	O-ring
208.1	Guiding ring
219	Grub screw
237	Spring

Table 1 Parts list for back pressure regulator BPV (Z version / K version)

5.3 Functioning of the back pressure regulator type BPV

The pressure difference at the back pressure regulator defined in the design shifts the control bush (item 204) in the direction of flow against the compression spring (item 237). As a result, the throttle cross sections at the bushing (item 206) open until the set pressure difference is reached.

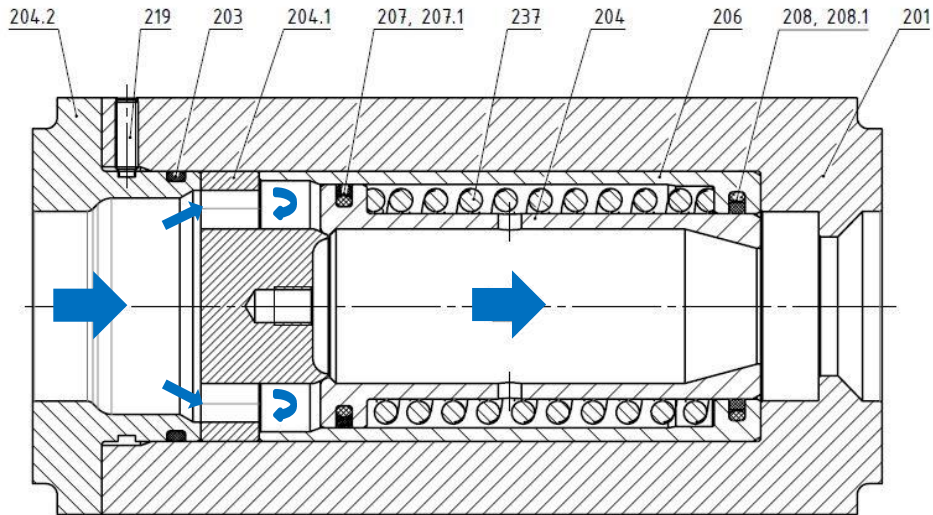

Figure 3 Valve BPV (Z version) in closed condition

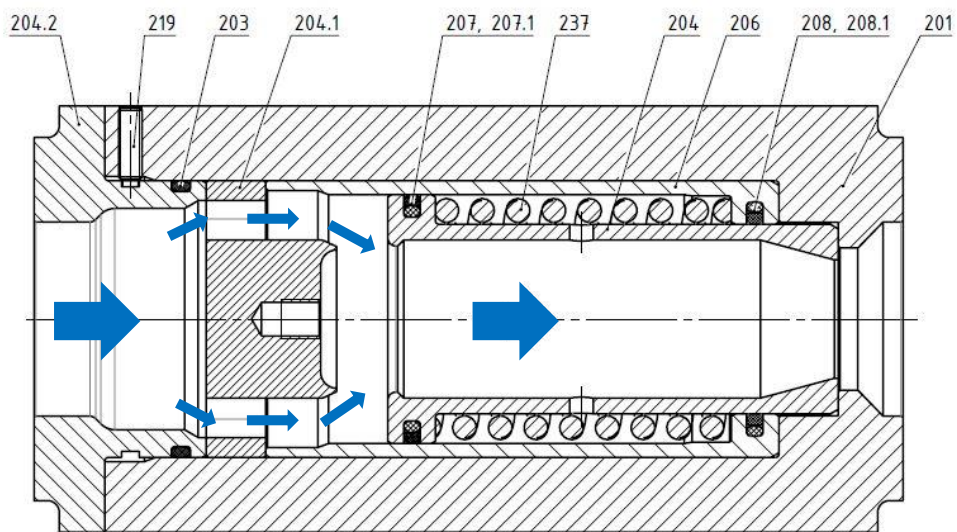

Figure 4 Valve BPV (Z version) in open condition

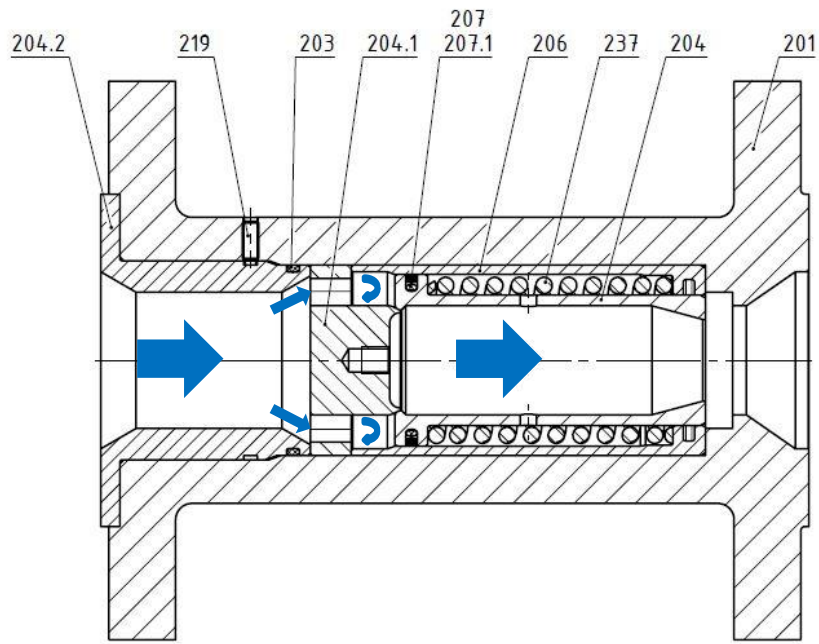

Figure 5 Valve BPV (K version) in closed condition

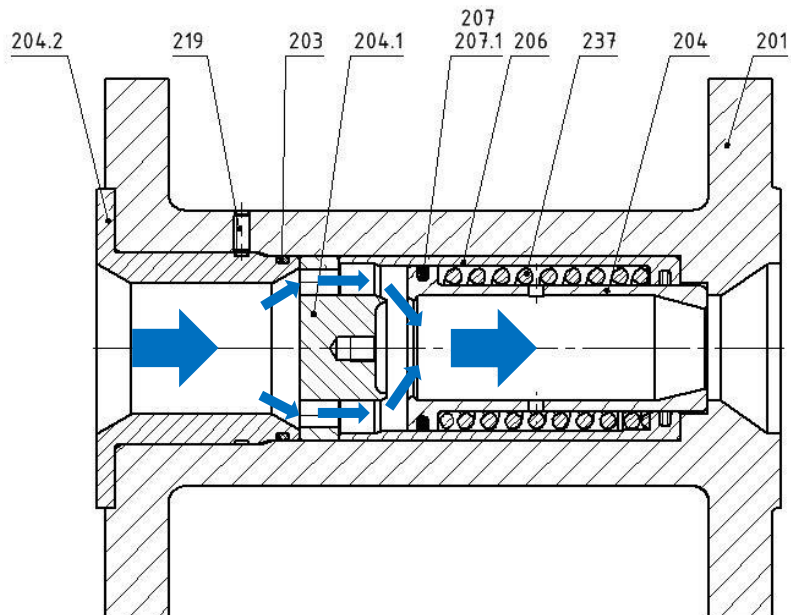

Figure 6 Valve BPV (K version) in open condition

5.4 General notes regarding operation of the valve

The optimum and refined pressure reduction of the SCHROEDAHL minimum flow rate valves and SCHROEDAHL control valves also set limits to extreme conditions in some systems.

In such cases, SCHROEDAHL back pressure regulators (BPV) are used. By generating a defined pressure differential, they increase the distance to the evaporating pressure of the medium. The undesired evaporation and cavitation is prevented, a smooth and gentle operation is ensured.

5.5 Identification of the valve

The specific technical data are provided on the back pressure regulator housing. The marking must contain at least the following information:

- Name of the manufacturer
- Nominal width
- PN designation
- Maximum allowable pressure PS
- Maximum allowable temperature TS
- Material
- Order number (serial number)
- Type of valve
- Year of manufacture
- CE marking (if necessary and possible)

Specific valve data are indicated on the valve nameplate as per sample below:

BPV055FZ-CS	
DN 25	PN 63
PS 56.0000 bar	TS 140.0000 °C
4001783.2-1	
➔	
11LAE11 BP001	
1.0460	
SCHROEDAHL GmbH	
2017	



Figure 7 Example of the marking on the housing of the back pressure regulator type BPV

In

the case of spare part deliveries, basically the order number (serial number), the type and the item number from the parts list should be indicated.

If within an order item several valves are supplied, then the nameplates should be additionally marked with order numbers / serial numbers beginning with "1". This ensures that the corresponding valves can be assigned.

6 Installation of the valve in the plant

6.1 Please observe before the installation in the pipeline!

	The valve must be installed when the pipeline is in a cooled condition. Valves, which are operated with high or low temperatures ($T > 60\text{ °C}$ or $T < 0\text{ °C}$), must be protected against accidental contact.
	The valve should be installed in the pipeline according to the flow arrows marked on the housing. It should be ensured that the flange pads and the seals are clean and free of damages, before tightening the bolts with the torque wrench for the appropriate tightening torque. Use only the provided bolts and seals of the manufacturer for installation of the valve in the plumbing system.
	Remove flange covers, if present.
	The inner parts of the valve and the pipeline must be free of foreign particles.
	Installation position of the valve with respect to the flow should be correctly maintained; see identification on the valve.
	For assembly work, appropriate transportation and lifting devices must be used. For weights, see catalogue sheet.
	In order to avoid damages to the flange pads and/or bolts, the valve assembly must be mounted in the plumbing system without stress.
	The valve should be installed as close as possible to the tank, preferably directly on the tank. There should be no elbows (tube bends) or cross section constrictions behind the BPV.

Unless agreed by a separate specification, the following should be considered prior to installation of the valve:

- Removal of the protective caps.
- Installation position, dimensions and weight of the valve should be documented in the dimension sheet and complied with.
- In the case of valves with a weight of over 25 kg, it is necessary to ensure that mounting lugs and lifting tools are available above the mounting location to a sufficient height.
- Prior to installation, the details of materials, pressure and temperature should be compared with the design and operating conditions of the plumbing system.
- Check the marking on the valve housing with the operating data of the system. Non-conformity may result in considerable damage to the valves for which the manufacturer is not liable.
- Check that sufficient space (hoist for assembly, etc.) is available at the installation location for easy installation and removal.
- Check that the pipeline has been flushed and cleaned before installation. If not, the manufacturer accepts no liability for the resulting damages.
- Check that the distance between pipe ends matches the valve length.
- Plumbing system must be correctly installed so that mechanical stresses (e.g., forces and moments from pipeline expansions during the operation, vibrations, etc.) do not act on the valve housing during installation and operation.
- Pipeline forces can be applied by the valve only to the extent, as they were considered by the specified pressure classes (flange geometry) and selection of material while planning the pipe system. Additional requirements need a special confirmation.

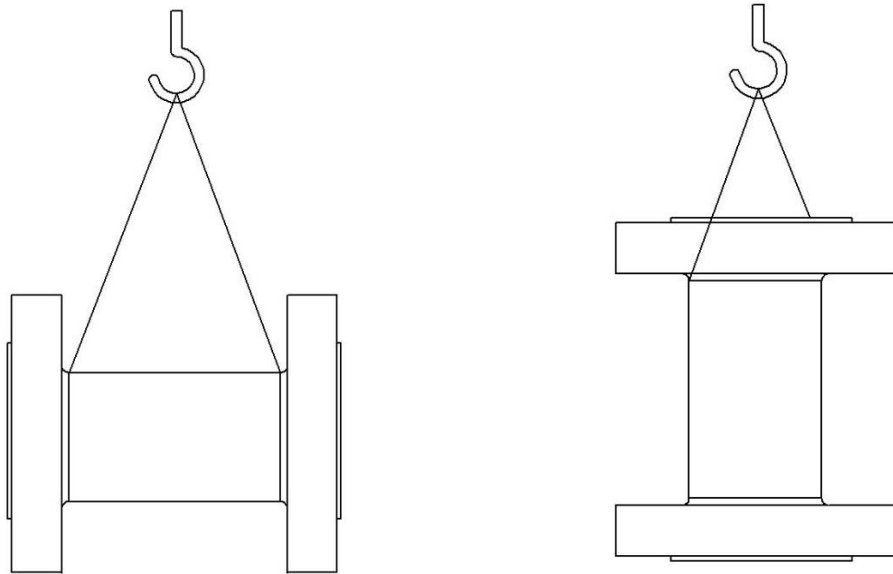

Figure 8 Typical representation of the handling options when installing the valve Type BPV (K version)

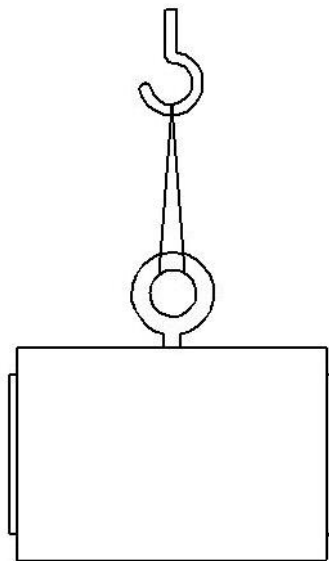

Figure 9 Typical representation of the handling options when installing the valve Type BPV (Z version)

Valve installation:

Installation example:

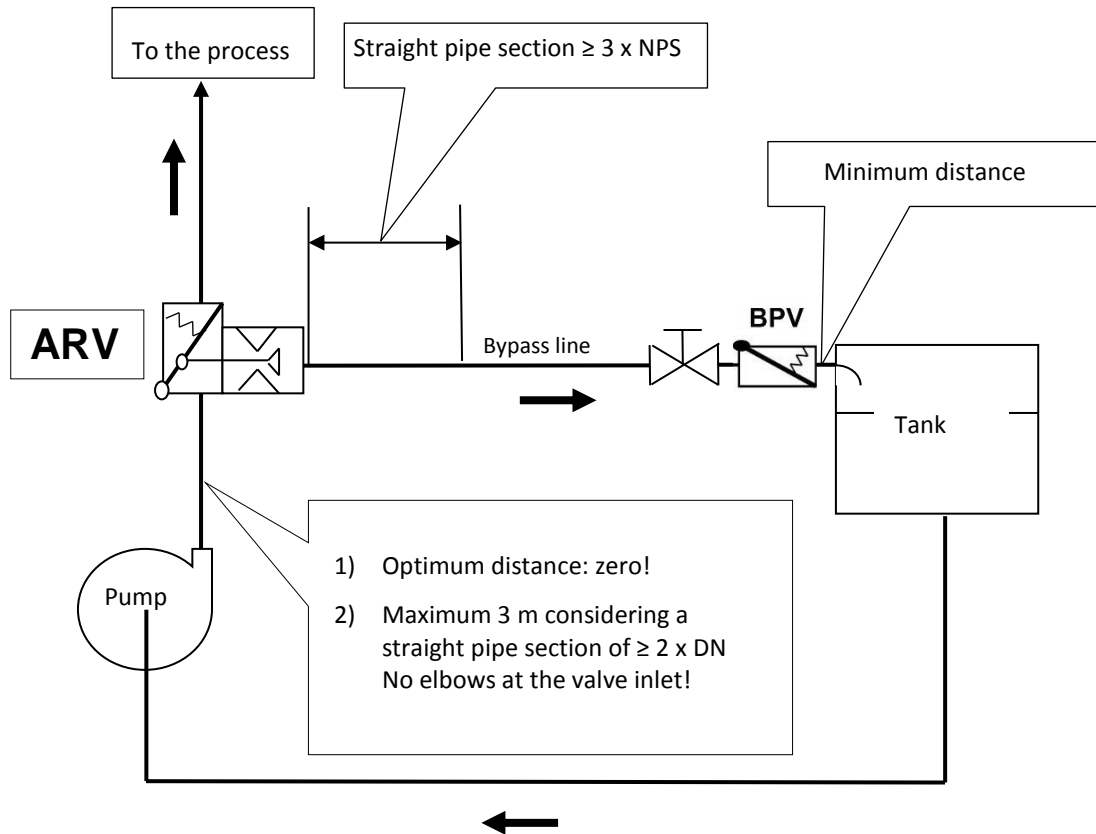

Figure 10 Schematic diagram of the installation conditions for the pump protection valve and back pressure regulator BPV (ARV instructions must also be observed)

<p>! NOTE</p>	<p>To prevent low frequency shocks caused by pulsation of the medium, the distance between pump outlet and valve inlet should not exceed 3 m with a straight pipe run at the inlet. Also a straight inlet pipe stretch should be provided. Deviations should be clarified with the manufacturer.</p>
<p>! NOTE</p>	<p>The recommended filter at the pump outlet should have a mesh size of 0.3 to 0.5 mm. For commissioning, we recommend a smaller mesh size for the filter (e.g. 0.1 mm).</p>

6.2 Installation of the valve

The sealing surfaces of the attachment flanges must be clean and without damages.

Flange gaskets must be mounted centrally and should not constrict the flow space.

The flanges should be carefully aligned before bolting. All provided flange holes must be used for the flange attachment. The bolts must be tightened according to the specifications given in the plumbing plan.

7 Pickling and flushing

The materials used in the valve are in general suitable for pickling. In practice, during pickling and flushing, impurities and foreign objects pass through the valves. This may result in damages to the trim parts.

During the flushing operation, the trim parts of the valve may be damaged by foreign objects.

Therefore, we recommend to replace the trims with appropriate protective inserts prior to pickling or flushing.

After pickling and flushing, the valve must be cleaned and the seals must be replaced.



Any foreign object, which remains in the valve after pickling or flushing, may damage the valve.

8 Removal of the valve



The valve must be without pressure, drained and in cooled condition.

Notes given in the corresponding dimension sheet must be followed

1. Suspend the valve, but do not lift.
2. Remove the flange bolts.
3. Remove the valve from the pipeline.
4. Store the valve in a protected condition.



The flange sealing surfaces of the valve must not be damaged during the removal of the pipeline and must be closed with suitable plastic caps or such like.

9 Disassembly and assembly of the valve

9.1 General assembly and disassembly information

Due to the high precision and close tolerances, maximum cleanliness and proper handling should be ensured. Any contamination or damage puts the proper operation in jeopardy.

No special tools are required for the assembly or disassembly of the valve.



DANGER

Before disassembling the valve, the valve must be without pressure, drained and in cooled condition! Also, remember that the piping on the bypass unit is part of the high-pressure stage!



WARNING

Before beginning any work ensure the following:

- Work correctly and safely according to the applicable regulations as well as the warnings and notes in this operating manual.
- Valves are pressure equipment! Any improper opening of the valve may endanger your health! The plant must be without pressure and dry before the disassembly.
- The pump must be switched off and secured against switching on again.
- Block the pipeline upstream and downstream of the valve.
- Remove the pressure from the pipe section.
- Allow the valve to cool to room temperature.
- Find out from the safety data sheet about the contents of the line and properly drain all hazardous and/or groundwater-endangering media from the blocked pipe section.
- Ensure the personal protective equipment prescribed in the safety data sheet.
- Immediately wipe away leakages and/or collect larger amounts or residues of medium in suitable containers.
- Always properly dispose of residues of medium (only in the case of hazardous media) in accordance with the Law on Waste. Never allow leakages/residues of medium seep into the sewerage system.





WARNING

Remove flange covers, if present.







WARNING

The interiors of the valve and the pipeline must be free of foreign particles.

 WARNING	Installation position of the valve (arrow punched onto housing) with respect to the flow should be correctly maintained; see identification on the valve Chapter 5.5.
 WARNING	For assembly work, appropriate transportation and lifting devices must be used. For weights see dimension sheet.
 WARNING	Special safety regulations and risk analyses must be performed before any maintenance, so that risks to humans and the environment are excluded!

9.2 Disassembly and inspection of the valve

 WARNING	Before disassembling the valve, the valve must be without pressure, drained and in cooled condition! Also, remember that the piping on the bypass unit is part of the high-pressure stage!
 WARNING	The pipeline system must be ventilated after prior emptying in the case of corrosive, combustible, aggressive or toxic media.

 NOTE	Please check before dismantling that sufficient spare parts and seals are available!
 NOTE	Spare parts have a delivery time of 12 weeks or more!

Procedure for removal:

1. Depressurise the system!
2. Remove the valve from the system (between bypass line and tank) (see Chapter 8).
3. Disassembly of the back pressure regulator using a press or special tools. Special tools are available from SCHROEDAHL.

 WARNING	Observe the preload of the spring (item 237)!
--	---

4. Loosen the two grub screws (item 219) and remove the elbow connection (item 204.2) from the housing (item 201).
5. Remove the orifice plate (item 204.1), control bush (item 204), spring (item 237) and bushing (item 206) from the housing.

Inspection:







1. Clean all parts and check for any damages.
2. In case of damage, the components must be replaced with new ones.
3. Replace O-rings (item 203/207/208) and guide rings (items 207.1 and 208.1).

9.3 Assembling the valve**Procedure for assembly:**

1. Insert the bushing (item 206) together with the new O-ring (item 208) and guide ring (208.1) into the housing (item 201).
2. Insert the spring (item 237) onto the standard bush (item 204) and push it together with the new O-ring (item 207) and guide ring (207.1) into the bushing (item 206).
3. Insert the orifice plate (item 204.1) into the housing (item 201) until it is in contact with (item 206).
4. Insert the elbow connection with the corresponding O-ring (item 203) into the housing (item 201) until it is in contact with the orifice plate (item 204.1) and fix it with both grub screws (item 219).

10 Commissioning

The valve is commissioned together with the back pressure regulator. When the main shut-off valve is closed in the main line, the specified minimum flow rate flows over the bypass and through the back pressure regulator. The correct function can be checked with a pressure measurement in the minimum flow pipe.



 WARNING	The valves must not be operated outside the permissible fields of application. The limits of usage can be found on the nameplate.
 WARNING	Residues in pipelines and valves (such as dirt, welding beads, etc.) cause leakages or damages.
 WARNING	When operating at high (> 50 °C) or low (< 0 °C) temperatures of the media, there is risk of injury when touching the valve. If necessary, put up warnings or make insulation protection!
 WARNING	Before each commissioning, after reworks and repairs, proper completion of all installation works must be ensured.
 NOTE	If the valve is operated with other operating data, then increased wear of the parts should be expected, depending on the variation in the design data. In the case of changed operating data, we recommend to consult the manufacturer, so that the valve can be specifically set to the operating conditions.
 NOTE	After commissioning, an inspection of the valve is recommended, in order to ensure that there are no damages to the valve!



11 Maintenance

The type BPV back pressure regulator is designed in such a way that no special maintenance is required. This is limited to cleaning the internal parts during regular maintenance of the pump or comparable system components and regular replacement of the seals, at the latest every 2 years. After disassembly of the valve, all seals should be replaced (by new seals) before reassembly.

The valve should be checked regularly.

We recommend a maintenance after commissioning and periodic changing of the seals, at least every 2 years.

 DANGER	<p>The valve is under pressure and usually at high temperature during operation. Non-compliance can result in death, serious bodily injuries or property damages.</p> <ul style="list-style-type: none"> • Assembly and maintenance work can only be carried out when the plant has been shut off and the valve is without pressure and has cooled down. • The plant should be commissioned again only after completion of the installation and maintenance work
 DANGER	<p>The valve can also still contain the medium in a pressure-free condition. Protection measures should be taken from the safety data sheets of the manufacturer of the medium!</p> <p>WARNING: Serious injuries possible!</p> <p>Suitable protective clothing is required for assembly and maintenance work.</p>

 NOTE	<p>Servicing and maintenance works must be carried out only by qualified personnel!</p>
 NOTE	<p>Standard spare parts have a delivery time of 12 weeks or more!</p>
 NOTE	<p>The operator is responsible for compliance with the safety regulations applicable at the place of erection!</p>

12 Inspections and inspection schedules

12.1 Inspections

The valve has been designed and manufactured, such that maximum quality and service friendliness is achieved. This results in a lower need for care and maintenance of the valve.

 NOTE	<p>The valve should be regularly subjected to a safety check in accordance with the company-specific safety regulations and statutory requirements. In this case, especially the pressurised components and connecting elements should be checked for wear and corrosion.</p>
--	---

Necessary checks before commissioning and after significant changes in the plant and repetitive checks should be carried out by the operator as required by the national regulations.

Please contact SCHROEDAHL for additional information.

12.2 Inspection schedules

We recommend inspection of the valve according to the Table below during the regular maintenance of the pump or pump systems, when plant is not operating, or at the latest every 2 years.

Components	Items						Inspection time	Measures
	201	204.2	219					
Housing	201	204.2	219				Maintenance of the pump or pump systems or or when the plant is not operating or every 2 years	Inspection
Internal parts	204	204.1	206	237				Check and replace if necessary
Seals	203	207	208					Replacement
Guiding rings	207.1	208.1						Inspection

Table 2 Test intervals for the components of the valve type BPV

13 Causes and remedies in the event of failures

In the case of failures or improper operation it is to be checked whether assembly and adjustments have been carried out and completed in accordance with this operating manual.

 WARNING	<p>Before beginning any work ensure the following:</p> <ul style="list-style-type: none">• Work correctly and safely according to the applicable regulations as well as the warnings and notes in this operating manual.• Valves are pressure equipment! Any improper opening of the valve may endanger your health! The plant must be without pressure and dry before the disassembly.• The pump must be switched off and secured against switching on again.• Block the pipeline upstream and downstream of the valve.• Remove the pressure from the pipe section.• Allow the valve to cool to room temperature.• Find out from the safety data sheet about the contents of the line and properly drain all hazardous and/or groundwater-endangering media from the blocked pipe section.• Ensure the personal protective equipment prescribed in the safety data sheet.• Immediately wipe away leakages and/or collect larger amounts or residues of medium in suitable containers.• Always properly dispose of residues of medium (only in the case of hazardous media) in accordance with the Law on Waste. Never allow leakages/residues of medium seep into the sewerage system.
---	---

 NOTE	For troubleshooting, follow the safety instructions in Chapter 2.3.!
---	--

If the measures below do not lead to a satisfactory result, the manufacturer/supplier must be contacted.

Defects	No.	Possible causes	Measures
1. No flow	1.1	<ul style="list-style-type: none"> Flange covers (transportation protection) not removed 	<ul style="list-style-type: none"> Remove flange covers (transportation protection)
	2.1	<ul style="list-style-type: none"> Contaminated strainer (dirt trap) 	<ul style="list-style-type: none"> Clean or replace the strainer
2. Low valve flow	2.2	<ul style="list-style-type: none"> Blockage in the plumbing system 	<ul style="list-style-type: none"> Check the plumbing system
	2.3	<ul style="list-style-type: none"> Back pressure in the bypass line set incorrectly or too low or BPV (back pressure controller) is defective 	<ul style="list-style-type: none"> At high pressures in the bypass line, the pressure must be about 4 bar higher than the vapour pressure of the medium (water). Increase in temperature (15 °C to 20 °C) of the medium due to the pump must be taken into account Increase the pressure in the tank or move BPV directly (as close as possible) to the tank Investigation of the vapour content after the BPV and the arrangement of the pipe to the tank Checking the dimensions of the BPV with existing operating data of the plant by the manufacturer
	2.4	<ul style="list-style-type: none"> The valve not installed in direction of flow 	<ul style="list-style-type: none"> Install the valve in the direction of flow
3. Functional failure or jamming of the valve	3.1	<ul style="list-style-type: none"> The plumbing system or medium not clean, possibly happens during commissioning 	<ul style="list-style-type: none"> Inspection of pipeline and valve, whether contaminants are present and clean accordingly. In the case of contaminated water, an additional filter (max. mesh size 0.5 mm) should be installed
	3.2	<ul style="list-style-type: none"> High wear or damage to the valve and/or bypass unit 	<ul style="list-style-type: none"> Replacement of the valve or worn components on the valve

4. Oscillations, vibrations and pressure surges in the valve	4.1	<ul style="list-style-type: none"> • Cavitation on the TDM bypass unit 	<ul style="list-style-type: none"> • Check the back pressure and, if necessary, increase
	4.2	<ul style="list-style-type: none"> • Minimum quantity of the pump too low 	<ul style="list-style-type: none"> • Inform the manufacturer
	4.3	<ul style="list-style-type: none"> • Dirty filter/strainer 	<ul style="list-style-type: none"> • Clean or replace the filter/strainer
	4.4	<ul style="list-style-type: none"> • Operating data of the system do not match with those given in the data sheet 	<ul style="list-style-type: none"> • Correct the operating data and forward the new operating data to manufacturer
	4.5	<ul style="list-style-type: none"> • Damaged trim parts 	<ul style="list-style-type: none"> • Inspection of the valve: clean or replace trim parts
	4.6	<ul style="list-style-type: none"> • Pump characteristic not stable due to unforeseen pump switching operations or quick shut-downs of the pump 	<ul style="list-style-type: none"> • Check operation of the pump and stabilise pump characteristic
	4.7	<ul style="list-style-type: none"> • Back pressure is too low and not stable 	<ul style="list-style-type: none"> • Forward to the manufacturer the details of arrangement of the pipes in the main and bypass lines for checking

Table 3 Causes and measures for malfunctions of the valve type BPV

Appendix

A.1 Form for the malfunction

		Meldung zur Betriebsstörung / Failure Report	
Achtung Attention		<p>Im Falle einer Störung ist dieses Formular ausgefüllt an Ihren Ansprechpartner bei Schroedahl zu senden. <i>In the case of a failure please fill out this report and send it back to your Schroedahl contact partner.</i></p>	
Allgemeine Information / General Information			
Anlagendaten / site information: <u>Name / Name:</u> <u>Adresse / Address:</u> <u>Land / Country:</u>		Ansprechpartner / contact partner: <u>Name / Name:</u> <u>Tel.-Nr. / Tel.-No.:</u> <u>Fax.-Nr. / Fax.-No.:</u> <u>Email:</u>	
Ventildaten / Valve information			
<u>Schroedahl Ventiltyp / valve type:</u> <u>Schroedahl Kommissionsnummer / serial number:</u> <u>Datum der Inbetriebnahme / date of commissioning:</u> <u>Betriebsstunden / operation hours:</u>			
Aktuelle Betriebsdaten der Pumpe / Current pump operating data			
<u>Zulaufdruck / suction pressure:</u> <u>Gegendruck Bypass / back pressure bypass:</u> <u>Enddruck / discharge pressure:</u> <u>Fördermenge / flow rate:</u> <u>Mindest kontinuierliche Prozessmenge / Minimum continuous process flow:</u> <u>Temperatur Fördermedium / medium temperature:</u>			
Beschreibung der Betriebsstörung / Description of failure			
<u>Datum der Störung / date of failure:</u> <u>Kurzbeschreibung der Störung / brief failure description:</u>			