

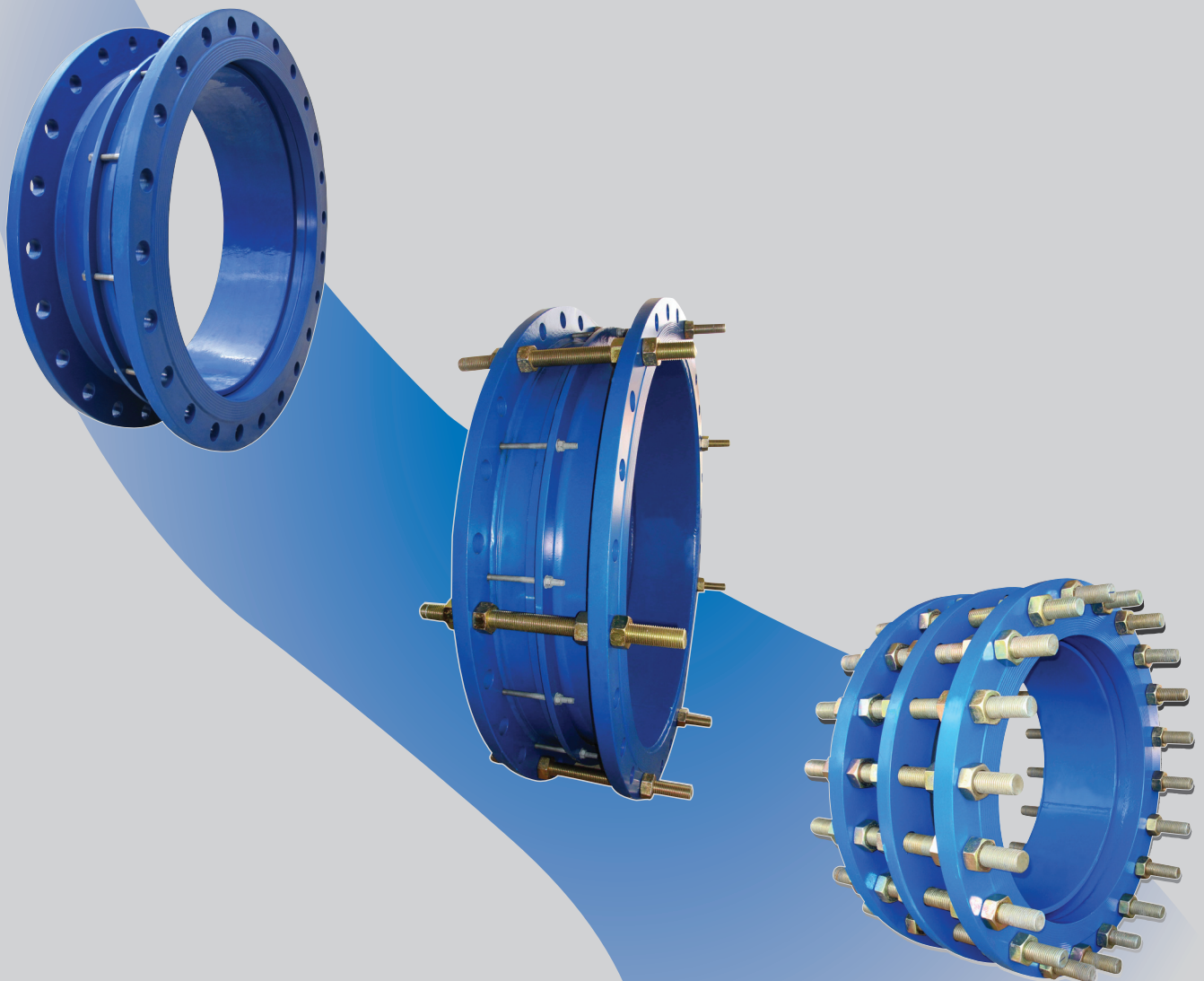

NeroValves GmbH

Dismantling Joint





Rigid Dismantling Joints - Type F1

Flange Drilling as per ISO 7005-1(EN 1092- 1, DIN 2501) Standard
 Pressure: PN10, PN16, PN25 & PN40

Features:

By using these joints, valves could easily be installed, removed/dismantled from the pipeline. By turning the bolts the length of the dismantling Joints can be reduced allowing enough space for removing the valve and sealing washers from the pipeline. For installing the valves and sealing washers, the length of dismantling joints can be adjusted by the adjusting bolts and therefore fastening the valve tightly to the pipe flanges.

Coating:

All parts are coated with electrostatic epoxy powder with minimum 250 micron suitable for potable water.

Material Specification:

Flangs Socket	Steel/Ductile Iron
Flangs Spigot	Steel/Ductile Iron
Middle Ring	Steel/Ductile Iron
Seal	EPDM or NBR
Rods & Nuts	Galvanized / Stainless Steel

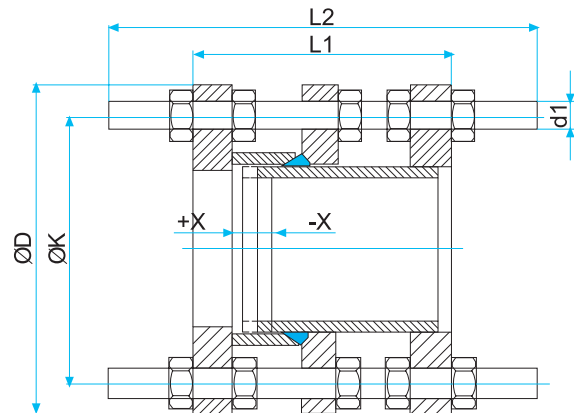

PN 10	DN	ØD (mm)	ØK (mm)	L1 (mm)	X (mm)	No. of holes	d1	L2 (mm)	Weight (Kg)
	50	165	125	195	± 25	4	M16	320	11
65	185	145	195	±25	4	M16	320	13	
80	200	160	195	± 25	8	M16	320	17	
100	220	180	195	± 25	8	M16	320	21	
125	250	210	195	± 25	8	M16	320	26	
150	285	240	225	± 25	8	M20	360	35	
200	340	295	225	± 25	8	M20	360	49	
250	395	350	225	± 25	12	M20	360	65	
300	445	400	225	± 25	12	M20	360	73	
350	505	460	225	± 25	16	M20	360	97	
400	565	515	250	± 25	16	M24	410	125	
450	615	585	250	± 25	20	M24	410	141	
500	670	620	250	± 25	20	M24	410	162	
600	780	725	260	± 25	20	M27	430	207	
700	895	840	260	± 25	24	M27	430	260	
800	1015	950	275	± 25	24	M30	465	355	
900	1115	1050	290	± 25	28	M30	465	408	
1000	1230	1160	300	± 25	28	M33	480	488	
1200	1455	1380	325	± 25	32	M36	530	750	
1400	1675	1590	340	± 25	36	M39	560	1037	
1600	1915	1820	365	± 25	40	M45	600	1525	
1800	2115	2020	380	± 25	44	M45	600	1830	
2000	2325	2230	420	± 25	48	M45	700	2280	



	DN	ØD (mm)	ØK (mm)	L1 (mm)	X (mm)	No. of holes	d1	L2 (mm)	Weight (Kg)
PN 16	50	165	125	195	± 25	4	M16	320	11
	65	185	145	195	± 25	4	M16	320	13
	80	200	160	195	± 25	8	M16	320	18
	100	220	180	195	± 25	8	M16	320	21
	125	250	210	195	± 25	8	M16	320	26
	150	285	240	225	± 25	8	M20	360	35
	200	340	295	225	± 25	12	M20	360	52
	250	405	355	235	± 25	12	M24	370	76
	300	460	410	250	± 25	12	M24	370	93
	350	520	470	250	± 25	16	M24	410	129
	400	580	525	255	± 25	16	M27	430	164
	450	640	585	270	± 25	20	M27	430	190
	500	715	650	275	± 25	20	M30	465	243
	600	840	770	285	± 25	20	M33	480	332
	700	910	840	285	± 25	24	M33	480	368
	800	1025	950	315	± 25	24	M36	530	480
	900	1125	1050	315	± 25	28	M36	530	548
	1000	1255	1170	335	± 25	28	M39	560	719
	1200	1485	1390	360	± 25	32	M45	600	1110
	1400	1685	1590	370	± 25	36	M45	600	1350
1600	1930	1820	420	± 25	40	M52	700	1822	
1800	2130	2020	420	± 25	44	M52	700	2555	
2000	2345	2230	445	± 25	48	M56	750	2645	
PN 25	50	165	125	195	± 25	4	M16	320	13
	65	185	145	195	± 25	8	M16	320	18
	80	200	160	215	± 25	8	M16	345	22
	100	235	190	220	± 25	8	M20	360	32
	125	270	220	225	± 25	8	M24	370	43
	150	300	250	245	± 25	8	M24	410	52
	200	360	310	245	± 25	12	M24	410	76
	250	425	370	250	± 25	12	M27	430	103
	300	485	430	265	± 25	16	M27	430	134
	350	555	490	290	± 25	16	M30	480	196
	400	620	550	295	± 25	16	M33	480	248
	450	670	600	295	± 25	20	M33	480	281
	500	730	660	315	± 25	20	M33	500	327
	600	845	770	320	± 25	20	M36	530	436
	700	960	875	325	± 25	24	M39	560	573
	800	1085	990	350	± 25	24	M45	600	800
	900	1185	1090	350	± 25	28	M45	600	888
	1000	1320	1210	400	± 25	28	M52	650	1272
	1200	1530	1420	440	± 25	32	M52	750	1870
	1400	1755	1640	460	± 25	36	M56	750	2050
1600	1975	1860	495	± 25	40	M56	810	2532	
1800	2195	2070	520	± 25	44	M64	880	2965	
2000	2425	2300	545	± 25	48	M64	900	3260	

Specification for sizes larger than 2000mm will be provided as per request.



Rigid Dismantling Joints - Type F2

Flange Drilling as per ISO 7005-1(EN 1092 – 1, DIN 2501) Standard
 Pressure: PN10, PN16, PN25 & PN40

Features:

By using these joints, valves could easily be installed, removed/dismantled from the pipeline. By turning the bolts the length of the dismantling Joints can be reduced allowing enough space for removing the valve and sealing washers from the pipeline. For installing the valves and sealing washers, the length of dismantling joints can be adjusted by the adjusting bolts and therefore fastening the valve tightly to the pipe flanges.

Preference: Quick and Easy installation to Type F1

Coating:

All parts are coated with electrostatic epoxy powder with minimum 250 micron suitable for potable water.

Material Specification:

Flangs Socket	Steel/Ductile Iron
Flangs Spigot	Steel/Ductile Iron
Middle Ring	Steel/Ductile Iron
Seal	EPDM or NBR
Rods, Bolts & Nuts	Galvanized / Stainless Steel

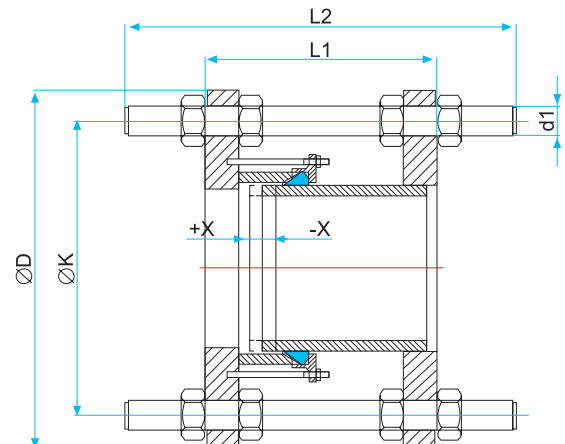

PN 10	DN	ØD (mm)	ØK (mm)	L1 (mm)	X (mm)	Flange Adaptor	Tie Stud Bolt No. & Dimensions			Weight (Kg)
						Stud Bolts No. & Dimensions	No. of holes	d1	L2 (mm)	
	50	165	125	195	± 25	2-M12	4	M16	320	8.3
	65	185	145	195	±25	2-M12	4	M16	320	9.3
	80	200	160	195	± 25	4-M12	4	M16	320	10.8
	100	220	180	195	± 25	4-M12	4	M16	320	12.1
	125	250	210	195	± 25	4-M12	4	M16	320	14.5
	150	285	240	225	± 25	4-M12	4	M20	360	21
	200	340	295	225	± 25	6-M12	4	M20	360	26.9
	250	395	350	225	± 25	6-M12	4	M20	360	33.8
	300	445	400	225	± 25	6-M12	4	M20	360	39.1
	350	505	460	225	± 25	8-M12	4	M20	360	67.7
	400	565	515	250	± 25	8-M12	4	M24	410	80.3
	450	615	585	250	± 25	10-M12	5	M24	410	89.7
	500	670	620	250	± 25	10-M12	5	M24	410	100
	600	780	725	260	± 25	10-M12	5	M27	430	124
	700	895	840	260	± 25	12-M12	6	M27	430	151
	800	1015	950	275	± 25	12-M12	6	M30	465	184
	900	1115	1050	290	± 25	14-M12	7	M30	465	205
	1000	1230	1160	300	± 25	14-M12	7	M33	480	271
	1200	1455	1380	325	± 25	16-M12	8	M36	530	448
	1400	1675	1590	340	± 25	18-M12	9	M39	560	547
	1600	1915	1820	365	± 25	20-M12	10	M45	600	1103
	1800	2115	2020	380	± 25	22-M12	11	M45	600	1176
	2000	2325	2230	420	± 25	24-M12	12	M45	700	1351



	DN	ØD (mm)	ØK (mm)	L1 (mm)	X (mm)	Flange Adaptor	Tie Stud Bolt No. & Dimensions			Weight (Kg)
						Stud Bolts No. & Dimensions	No. of holes	d1	L2 (mm)	
PN 16	50	165	125	195	± 25	2-M12	4	M16	320	8.3
	65	185	145	195	±25	2-M12	4	M16	320	9.3
	80	200	160	195	± 25	4-M12	4	M16	320	10.8
	100	220	180	195	± 25	4-M12	4	M16	320	12.1
	125	250	210	195	± 25	4-M12	4	M16	320	14.5
	150	285	240	225	± 25	4-M12	4	M20	360	21
	200	340	295	225	± 25	6-M12	4	M20	360	29.2
	250	405	355	235	± 25	6-M12	4	M24	410	39.9
	300	460	410	250	± 25	6-M12	4	M24	410	46.8
	350	520	470	250	± 25	8-M12	4	M24	410	63.8
	400	580	525	255	± 25	8-M12	4	M27	430	87.5
	450	640	585	270	± 25	10-M12	5	M27	430	102
	500	715	650	275	± 25	10-M12	5	M30	465	123
	600	840	770	285	± 25	10-M12	6	M33	480	159
	700	910	840	285	± 25	12-M12	6	M33	480	167
	800	1025	950	315	± 25	12-M12	6	M36	530	199
	900	1125	1050	315	± 25	14-M16	7	M36	530	223
	1000	1255	1170	335	± 25	14-M16	7	M39	560	300
	1200	1485	1390	360	± 25	16-M16	8	M45	600	508
	1400	1685	1590	370	± 25	18-M16	9	M45	600	602
1600	1930	1820	420	± 25	20-M16	10	M52	700	1188	
1800	2130	2020	420	± 25	22-M16	11	M52	700	1363	
2000	2345	2230	445	± 25	24-M16	12	M56	750	1594	
PN 25	50	165	125	195	± 25	2-M12	4	M16	320	8.3
	65	185	145	195	±25	2-M12	4	M16	320	9.3
	80	200	160	215	± 25	4-M12	4	M16	320	10.8
	100	235	190	220	± 25	4-M12	4	M20	360	19.9
	125	270	220	225	± 25	4-M12	4	M20	370	25.6
	150	300	250	245	± 25	4-M12	4	M24	410	29.8
	200	360	310	245	± 25	6-M12	4	M24	410	37
	250	425	370	250	± 25	6-M12	4	M27	430	48.4
	300	485	430	265	± 25	8-M12	4	M27	430	56.3
	350	555	490	290	± 25	8-M12	4	M30	480	89.1
	400	620	550	295	± 25	8-M12	4	M33	480	107
	450	670	600	295	± 25	10-M12	5	M33	480	118
	500	730	660	315	± 25	10-M12	5	M33	500	133
	600	845	770	320	± 25	10-M12	6	M33	530	167
	700	960	875	325	± 25	12-M12	6	M39	560	215
	800	1085	990	350	± 25	12-M16	6	M45	600	285
900	1185	1090	350	± 25	14-M16	7	M45	600	346	
1000	1320	1210	400	± 25	14-M16	7	M52	650	517	

Specification for sizes larger than 2000mm will be provided as per request.

Rigid Dismantling Joints - Type F3

Flange Drilling as per ISO 7005-1(EN 1092 – 1, DIN 2501) Standard

Pressure: PN10, PN16, PN25 & PN40

Features:

Non Rigid dismantling joints in addition to pedestrian and assembly of valves can neutralize line's angle up to $^{\circ} 4\pm$, they have also ability to neutralize the vibrations, these parts due to special design and has the ability to withstand high pressures.

Coating:

All parts are coated with electrostatic epoxy powder with minimum 250 micron suitable for potable water.

Material Specification:

Flangs Socket	Steel/Ductile Iron
Flangs Spigot	Steel/Ductile Iron
Middle Ring	Steel/Ductile Iron
Seal	EPDM or NBR
Rods & Nuts	Galvanized / Stainless Steel

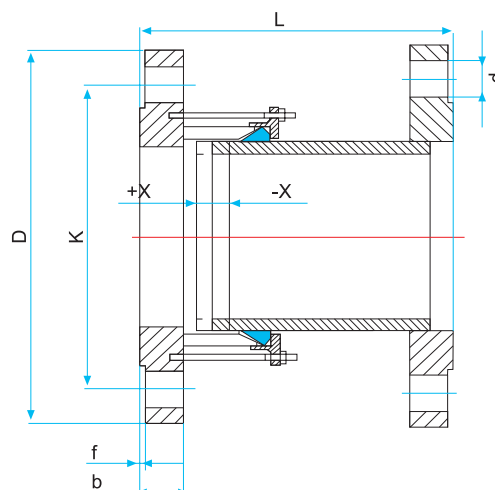

DN	ØD (mm)	ØK (mm)	L (mm)	No. of holes	PN 10
65	185	145	300	4	
80	200	160	300	8	
100	220	180	300	8	
125	250	210	300	8	
150	285	240	300	8	
200	340	295	300	8	
250	395	350	350	12	
300	445	400	350	12	
350	505	460	350	16	
400	565	515	380	16	
450	615	565	380	20	
500	670	620	380	20	
600	780	725	380	20	
700	895	840	380	24	
800	1015	950	380	24	
900	1115	1050	380	28	
1000	1230	1160	380	28	
1200	1455	1380	400	32	
1400	1675	1590	400	36	
1600	1915	1820	400	40	
1800	2115	2020	450	44	
2000	2325	2230	450	48	

DN	ØD (mm)	ØK (mm)	L (mm)	No. of holes	PN 16
65	185	145	300	4	
80	200	160	300	8	
100	220	180	300	8	
125	250	210	300	8	
150	285	240	300	8	
200	340	295	300	12	
250	405	355	350	12	
300	460	410	350	12	
350	520	470	350	16	
400	580	525	380	16	
450	640	585	380	20	
500	715	650	380	20	
600	840	770	380	20	
700	910	840	380	24	
800	1025	950	380	24	
900	1125	1050	380	28	
1000	1255	1170	380	28	
1200	1485	1390	400	32	
1400	1685	1590	400	36	
1600	1930	1820	400	40	
1800	2130	2020	450	44	
2000	2345	2230	450	48	

Specification for sizes larger than 2000mm will be provided as per request.



NeroValves GmbH

Industrial Valves: DIN - API - ASME

Nordend Str. 48
64546 Morfelden-
walldorf / Germany

Tel: +49-(0) 6105-408 188-0

Fax: +49-(0) 6105-408 188-5

Email: info@nero-valvesgmbh.de

www.nero-valvesgmbh.de;

www.nero-valves.com