



KF Valves

Check Valves



Continuously Improving
Flow Control

High Performance By Design

Applicable Standards

KF check valves conform to ANSI, API and NACE specifications to meet your application requirements.

ANSI - American National Standard Institute

B 16.34

Specification steel valves.

B 16.5

Flanges & flanged fittings.

API - American Petroleum Institute

Spec. 6A

Specification for wellhead equipment.

Spec. 6D

Specification for pipeline valves.

Spec. 6FD

Specification for fire ratings.

Hydrogen Sulfide (H₂S Environments)

NACE MRO175/ISO 15156

General principles for cracking resistant materials in H₂S containing environments in oil & gas production.

This catalog details the many ways KF check valves work for you. Contact us today for the representative or distributor nearest you. KF Check Valves are not intended for pulsating reciprocating service except for the series 50 piston check valve.

KF Valves has continuously provided the industry with technically superior products oriented toward applications that can be exceptionally severe. KF's diversity in check valve configurations and materials of construction provide opportunities to service customers in many different markets. KF check valve designers plan for your worst applications so you get the very best regardless

of the factors involved— pressure, environment, media transported and cost. Whether it's critical control of waste water flow, highly corrosive refining applications or high pressure in the oil patch, KF offers a wide range of sizes, materials, options, efficient design and stringent manufacturing standards. Specifying KF check valves guarantees you a valve optimally designed for your application.



You'll Find KF Check Valves Utilized in the Following Industries

- > Geothermal
- > Refining
- > Marine
- > Industrial
- > Mining
- > Refrigeration
- > Iron & steel mills
- > Oil & gas production
- > Automotive manufacturing
- > CO₂ injection/recovery
- > Pulp & paper
- > Oilfield production to NASA
- > Food processing
- > Ethanol
- > Water/waste water
- > HVAC
- > Desalination
- > Waterflood

KF Series 10 Check Valves

Features

- > Designed to comply with API 6D, API 6A & API 594 specifications
- > Available in a wide range of materials including 316 stainless steel trim
- > NACE MR0175/ISO 15156 (optional)

Flangeless bodied wafer style design with round port and spring assisted closure. Offered in 2" thru 12" class 150, 300 & 600

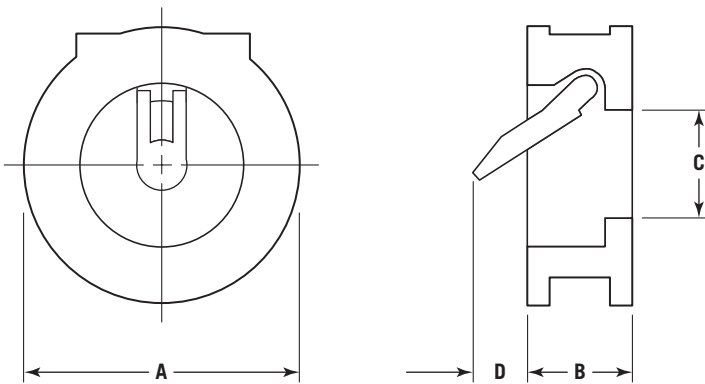

Dimensional Data (in., mm), 2"-12", Class 150, 300 & 600

Dim./Class (in., mm)	Size (in.)														
	2		3		4		6		8		10		12		
	in.	mm	in.	mm	in.	mm	in.	mm	in.	mm	in.	mm	in.	mm	
A	150	4.13	104.8	5.38	136.5	6.88	174.6	8.75	222.3	11.00	279.4	13.38	339.7	16.13	409.6
	300	4.38	111.1	5.88	149.2	7.13	181.0	9.88	250.8	12.13	308.0	14.25	362.0	16.63	422.3
	600	4.38	111.1	5.88	149.2	7.63	193.7	10.50	266.7	12.63	320.7	15.65	397.0	18.00	457.2
B	300	2.38	60.3	2.88	73.0	2.88	73.0	3.88	98.4	5.00	127.0	5.75	146.1	7.13	181.0
	600	2.38	60.3	2.88	73.0	3.13	79.4	5.38	136.5	6.50	165.1	8.38	212.7	9.00	228.6
C	300	1.53	38.9	2.06	52.4	3.03	77.0	4.75	120.7	6.44	163.5	7.63	193.7	9.50	241.3
	600	1.53	38.9	2.06	52.4	3.03	77.0	4.75	120.7	6.44	163.5	7.63	193.7	9.50	241.3
D	150	.50	12.7	.75	19.1	1.50	38.1	3.38	85.7	3.50	88.9	4.44	112.7	5.09	129.4
	300	.25	6.35	.75	19.1	1.25	31.8	3.38	85.7	3.50	88.9	4.44	112.7	5.09	129.4
	600	.25	6.35	.75	19.1	1.25	31.8	1.88	47.6	2.00	50.8	2.00	50.8	3.22	81.8
Weight (lbs., kg)	150	5	2.3	11	5.0	16	7.3	30	13.6	50	22.7	90	40.8	145	65.8
	300	8	3.6	18	8.2	24	10.9	56	25.4	70	31.8	135	61.2	211	95.7
	600	8	3.6	18	8.2	31	14.1	62	28.1	167	75.7	354	160.6	465	210.9

Contact factory for series 10G weights and "B" dimensions.

KF Series 10 & 10G Check Valve Part Number Codes

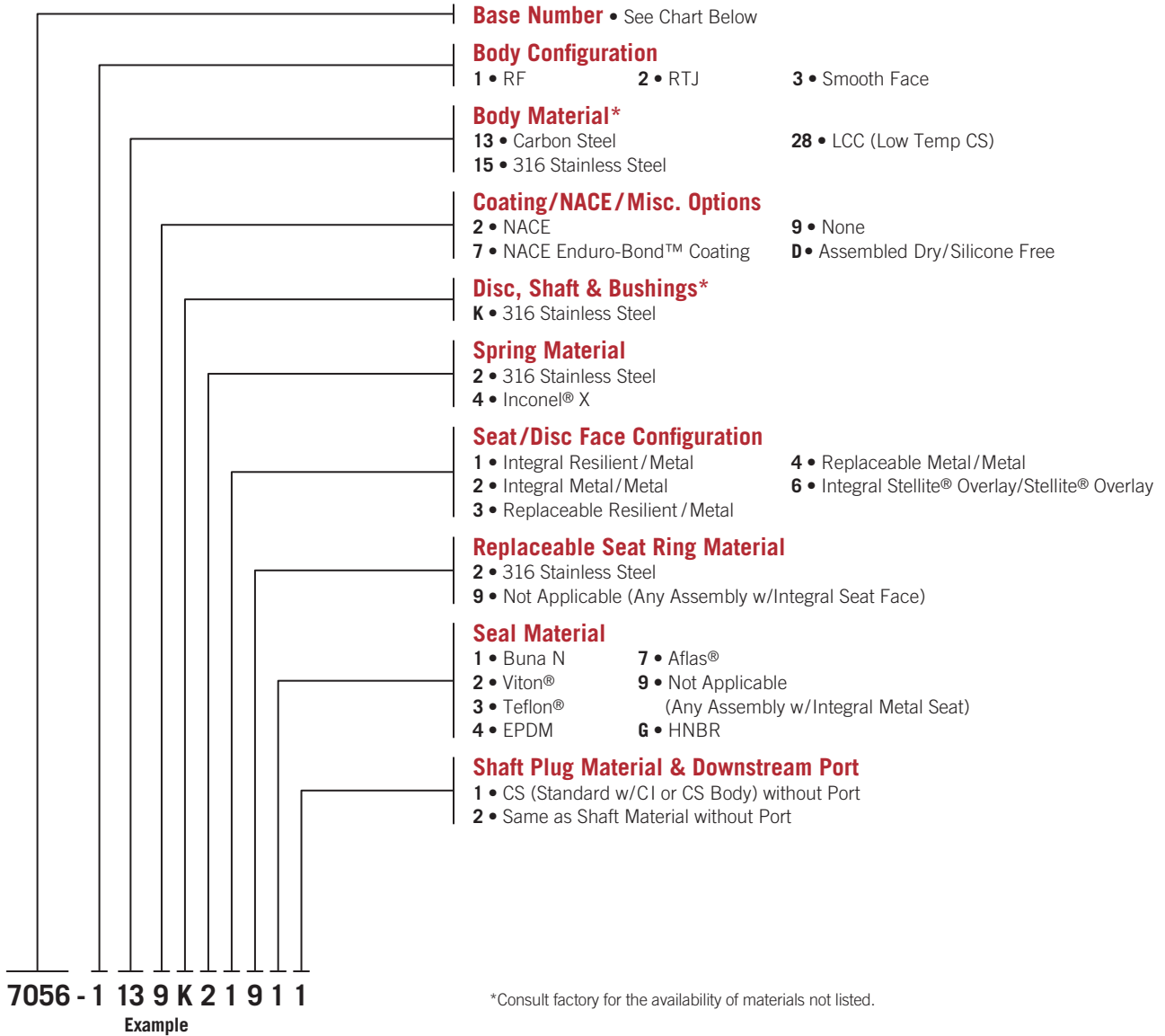

Series 10 Assembly Base Numbers

Class	MOP	Size (in.)						
		2	3	4	6	8	10	12
150	285	7087-	7089-	7090-	7092-	7093-	7094-	7095-
300	740	7120-	7122-	7123-	7125-	7126-	7127-	7128-
600	1480	7179-	7181-	7182-	7184-	7185-	7186-	7187-

Series 10G Assembly Base Numbers (Non API 594)

Class	Size (in.)								
	2	2 1/2	3	4	5	6	8	10	12
150	7313-	7314-	7315-	7316-	7317-	7318-	7319-	7320-	7321-

KF Series 12 Check Valves

Features

- Standard 316 stainless steel disc on 2" thru 4"

Designed to comply with API 6D specifications for short pattern wafer check valves.

Offered in 2" thru 12"

class 150 • 285 psi MOP

class 300 • 740 psi MOP

class 600 • 1480 psi MOP

class 900 • 2220 psi MOP

2" thru 8", class 1500 • 3705 psi MOP

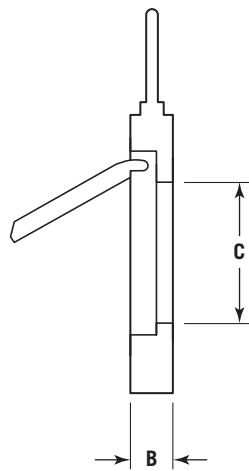
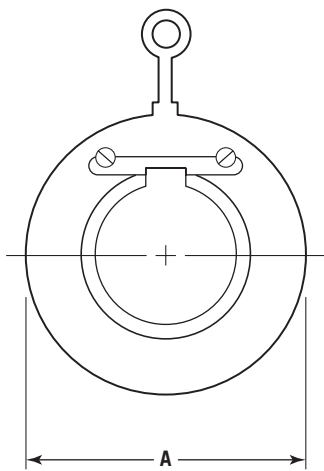

Dimensional Data (in., mm), 2"-12", Class 150, 300, 600, 900 & 1500

Dim./Class (in., mm)	Size (in.)														
	2		3		4		6		8		10		12		
	in.	mm	in.	mm	in.	mm	in.	mm	in.	mm	in.	mm	in.	mm	
A	150	4.13	104.8	5.38	136.5	6.88	174.6	8.75	222.3	11.00	279.4	13.38	339.7	16.13	409.6
	300	4.38	111.1	5.88	149.2	7.13	181.0	9.88	250.8	12.13	308.0	14.25	362.0	16.63	422.3
	600	4.38	111.1	5.88	149.2	7.63	193.7	10.50	266.7	12.63	320.7	15.75	400.1	18.00	457.2
	900	5.63	142.9	6.63	168.3	8.13	206.4	11.38	288.9	14.13	358.8	17.13	435.0	19.63	498.5
	1500	5.63	142.9	6.88	174.6	8.25	209.6	11.13	282.6	13.88	352.4	—	—	—	—
B	150	.75	19.1	.75	19.1	.75	19.1	.75	19.1	1.13	28.6	1.13	28.6	1.50	38.1
	300	.75	19.1	.75	19.1	.75	19.1	.88	22.2	1.13	28.6	1.50	38.1	2.00	50.8
	600	.75	19.1	.75	19.1	.88	22.2	1.13	28.6	1.50	38.1	2.25	57.2	2.38	60.3
	900	.75	19.1	.75	19.1	.88	22.2	1.38	34.9	1.75	44.5	2.25	57.2	3.13	79.4
	1500	.75	19.1	.88	22.2	1.25	31.8	1.75	44.5	2.25	57.2	—	—	—	—
C	150-300	1.06	27.0	1.88	47.6	2.93	74.3	4.50	114.3	5.63	142.9	7.50	190.5	8.69	220.7
	600-900	1.06	27.0	1.88	47.6	2.63	66.7	4.13	104.8	5.00	127.0	7.00	177.8	8.50	215.9
	1500	1.06	27.0	1.63	41.3	2.50	63.5	4.13	104.8	5.00	127.0	—	—	—	—
Weight (lbs., kg)	150	3	1.4	5	2.3	6	2.7	12	5.4	24	10.9	32	14.5	62	28.1
	300	3	1.4	6	2.7	7	3.2	15	6.8	29	13.2	60	27.2	103	46.7
	600	4	1.8	6	2.7	8	3.6	20	9.1	33	15.0	110	49.9	150	68.0
	900	4	1.8	7	3.2	12	5.4	24	10.9	57	25.9	131	59.4	234	106.1
	1500	4	1.8	9	4.1	19	8.6	49	22.2	74	33.6	—	—	—	—

KF Series 12 Check Valve Part Number Codes

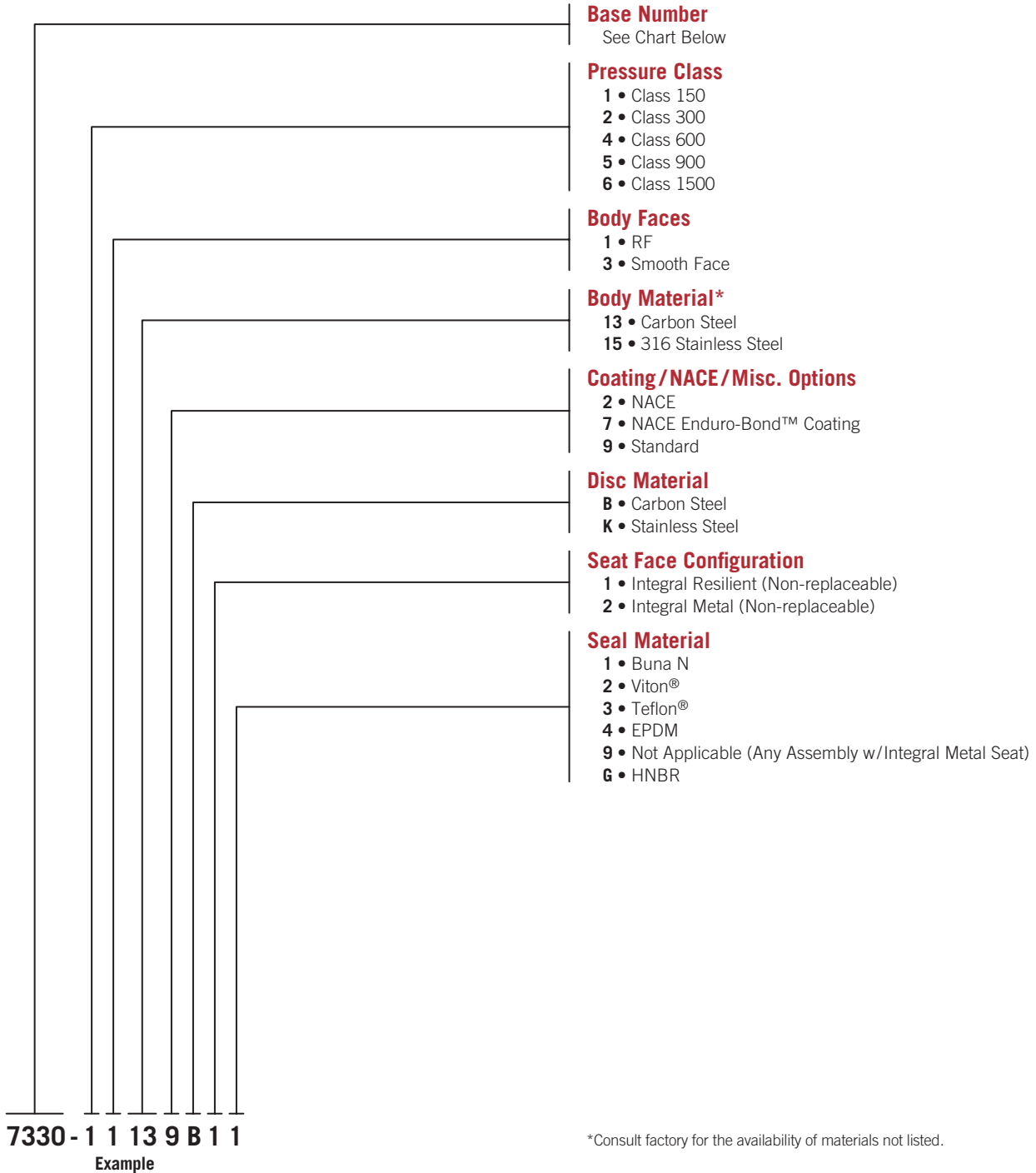

Assembly Base Numbers

Size (in.)						
2	3	4	6	8	10	12
7330-	7332-	7333-	7335-	7336-	7337-	7338-

KF Series 18 Check Valves

Features

- > Externally adjustable shaft packing gland & back-flush lever is standard
- > Available with either right-hand or left-hand lever orientation

Flangeless bodied wafer with non-API lay length swing style check valve with external spring assisted closure. Offered in 4" thru 12" class 150



Note: KF Right-Hand Version Shown

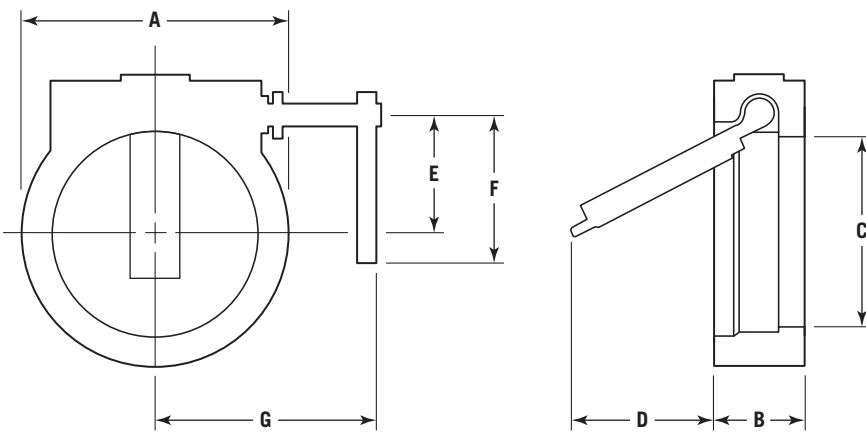

Dimensional Data (in., mm), 4"-12", Class 150

Dimension (in., mm)	Size (in.)									
	4		6		8		10		12	
	in.	mm	in.	mm	in.	mm	in.	mm	in.	mm
A	6.88	174.6	8.75	222.3	11.00	279.4	13.38	339.7	16.13	409.6
B	2.25	57.2	2.75	69.9	2.88	73.0	3.13	79.4	3.50	88.9
C	3.03	77.0	4.75	120.7	6.44	163.5	7.63	193.7	9.50	241.3
D	2.50	63.5	4.00	101.6	5.50	139.7	7.00	177.8	9.50	241.3
E	2.28	57.9	3.25	82.6	4.03	102.4	4.75	120.7	5.88	149.2
F	7.00	177.8	7.00	177.8	11.25	285.8	13.00	330.2	15.00	381.0
G	6.25	158.8	7.50	190.5	8.50	215.9	10.50	266.7	12.50	317.5
Weight (lbs., kg)	14	6.4	25	11.3	33	15.0	55	24.9	78	35.4

KF Series 18 Check Valve Part Number Codes

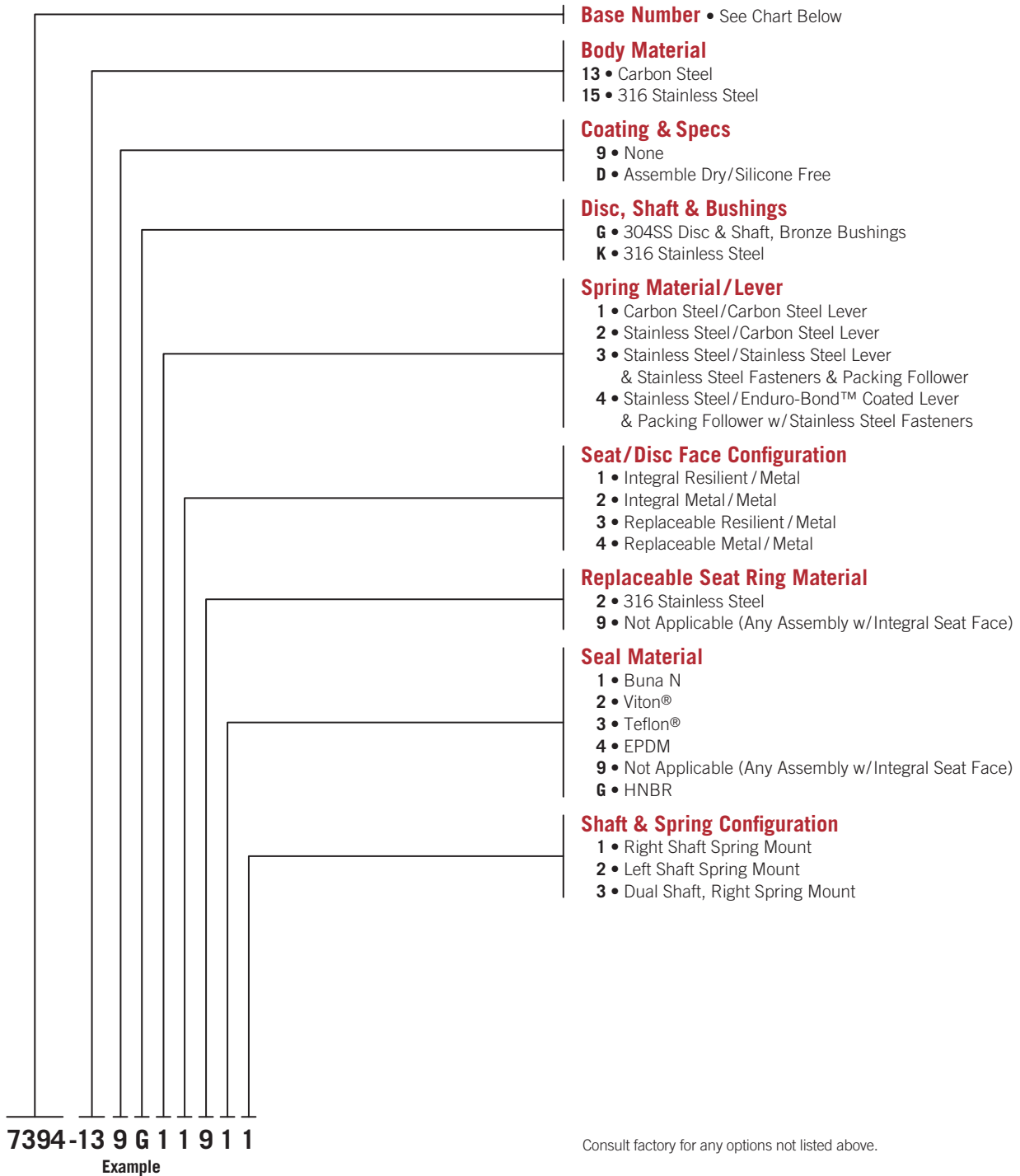

Assembly Base Numbers

Class	MOP	Size (in.)				
		4	6	8	10	12
150	285	7392-	7394-	7395-	7396-	7397-

KF Series 20 & 22 Check Valves

Features

- > Externally adjustable shaft packing is standard
- > Available with either right-hand, left-hand or double extended lever/shaft orientation
- > Standard flush port connection
- > Series 22 air cushion dampens final 10% of closure
- > Series 20 modifiable in the field to accept series 22 air cushion

Semi-lug, flangeless bodied swing style design with externally adjustable spring assisted closure.
 Offered in 2" thru 72"
 class 150 • 285 psi MOP
 class 300 • 740 psi MOP
 2" thru 24"
 class 600 • 1480 psi MOP

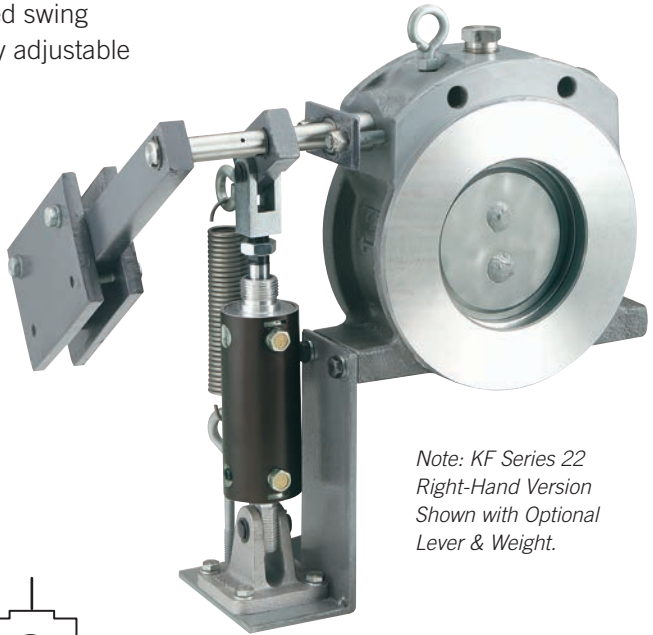

Note: KF Series 22 Right-Hand Version Shown with Optional Lever & Weight.

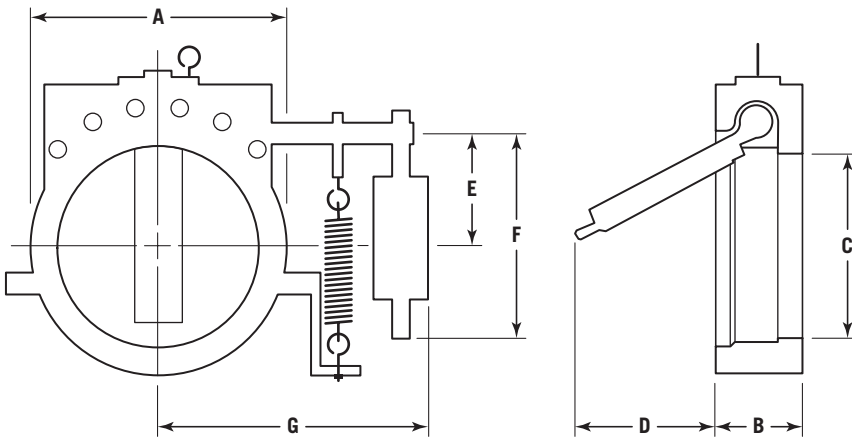

Dimensional Data (in., mm), 2"-30", Class 150

Dimension	Size (in.)												
	2	3	4	6	8	10	12	14	16	18	20	24	30
A	4.13	5.38	6.88	8.63	10.88	13.25	16.00	17.63	20.13	21.50	23.75	28.13	34.50
B	3.75	3.75	3.75	3.75	3.75	4.75	4.75	7.75	8.75	8.75	9.75	9.75	9.75
C	1.50	2.06	3.03	4.75	6.56	7.63	9.50	10.19	11.00	12.50	15.13	18.63	23.63
D	.41	.78	1.38	3.41	5.41	6.13	7.88	7.06	8.06	9.75	11.50	14.34	22.06
E	1.22	1.80	2.27	3.34	4.38	5.34	6.38	7.00	8.13	9.00	10.88	12.25	15.50
F	6.63	9.88	9.88	12.50	12.50	12.50	17.00	30.00	30.00	30.00	31.50	31.50	31.50
G	8.75	9.75	9.75	11.50	13.50	14.50	16.50	20.25	22.25	23.25	27.00	31.00	36.75
Weight (lbs.)	29	39	52	73	88	152	220	320	445	582	763	897	1360
Dimension	Size (mm)												
	A	104.8	136.5	174.6	219.1	276.2	336.6	406.4	447.7	511.2	546.1	603.3	714.4
B	95.3	95.3	95.3	95.3	95.3	120.7	120.7	196.9	222.3	222.3	247.7	247.7	247.7
C	38.1	52.4	77.0	120.7	166.7	193.7	241.3	258.8	279.4	317.5	384.2	473.1	600.1
D	10.3	19.8	34.9	86.5	137.3	155.6	200.0	179.4	204.8	247.7	292.1	364.3	560.4
E	31.0	45.6	57.5	84.9	111.1	135.7	161.9	177.8	206.4	228.6	276.2	311.2	393.7
F	168.3	250.8	250.8	317.5	317.5	317.5	431.8	762.0	762.0	762.0	800.1	800.1	800.1
G	222.3	247.7	247.7	292.1	342.9	368.3	419.1	514.4	565.2	590.6	685.8	787.4	933.5
Weight (kg)	13.2	17.7	23.6	33.1	39.9	68.9	99.8	145.1	201.8	264.0	346.1	406.9	616.9



KF Valves

KF Series 20 & 22 Check Valve Part Number Codes

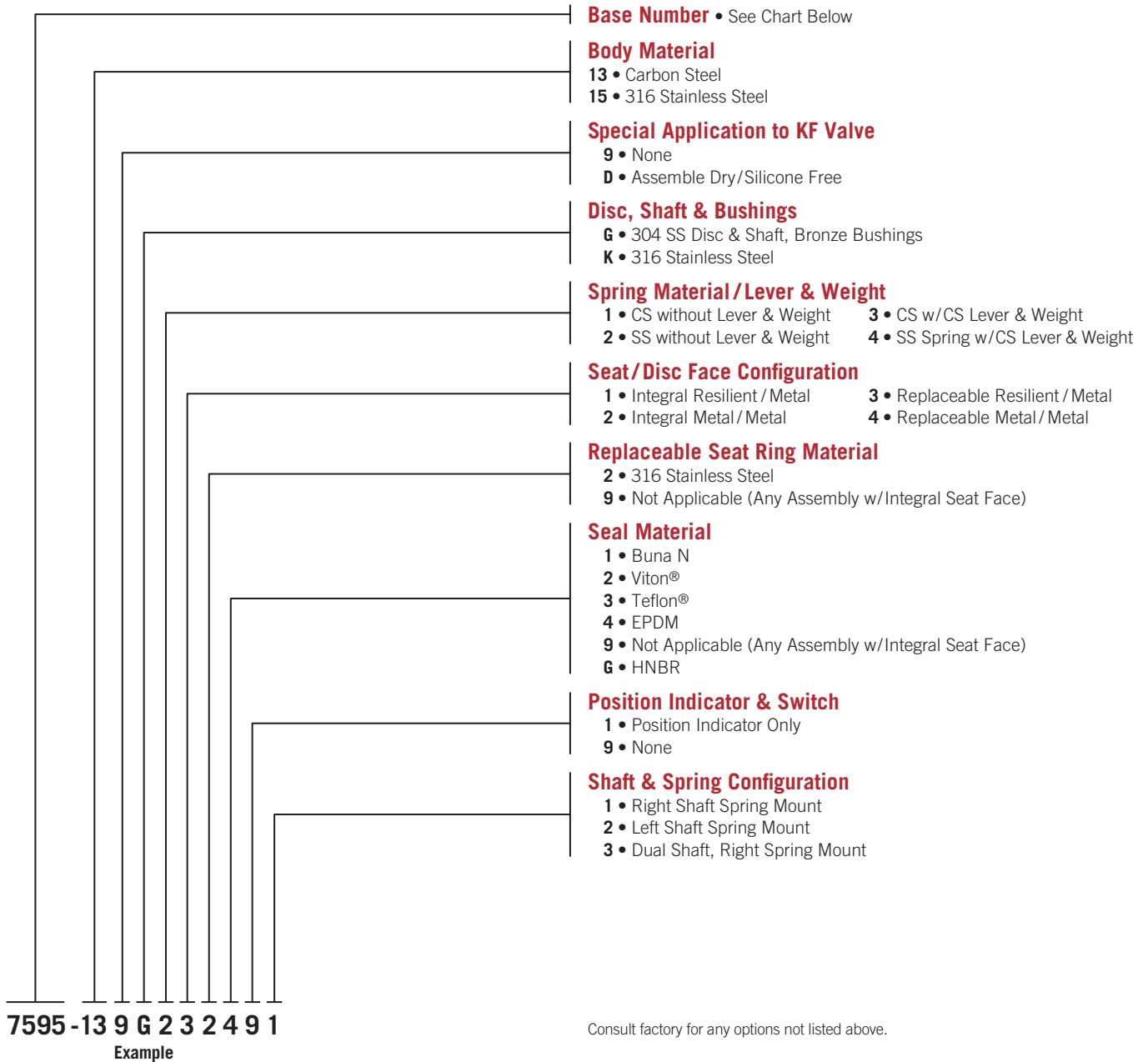

Assembly Base Numbers, Series 20

Class	Size (in.)												
	2	3	4	6	8	10	12	14	16	18	20	24	30
150	7458-	7460-	7461-	7463-	7464-	7465-	7466-	7467-	7468-	7469-	7470-	7472-	7473-

Assembly Base Numbers, Series 22

Class	Size (in.)												
	2	3	4	6	8	10	12	14	16	18	20	24	30
150	7583-	7585-	7586-	7588-	7589-	7590-	7591-	7592-	7593-	7594-	7595-	7597-	7598-

KF Series 31 Check Valves

Features

- > Available in ductile iron, carbon steel & 316 stainless steel, 316 stainless steel trim is standard
- > Acceptable for vertical "upflow" applications & suitable for pigging
- > Standard seating configuration has o-ring seal located in disc for ease of replacement
- > NACE MR0175/ISO 15156

Threaded, grooved and socketweld end connections swing style design with threaded bonnet.
 Offered in ductile iron, 1" thru 4" 300, 600, 750, 1000, 1500 & 2000 psi MOP
 carbon steel, 1" thru 4" 300, 750, 1500, & 2220 psi MOP
 1" thru 3" • 3000 psi MOP
 1" only • 5000 psi MOP



Part Number Codes

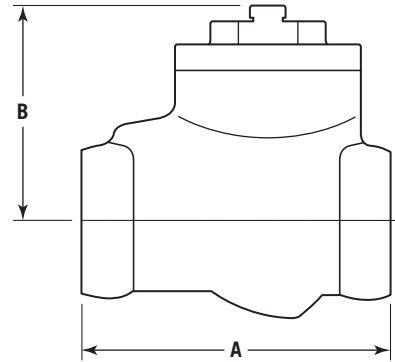
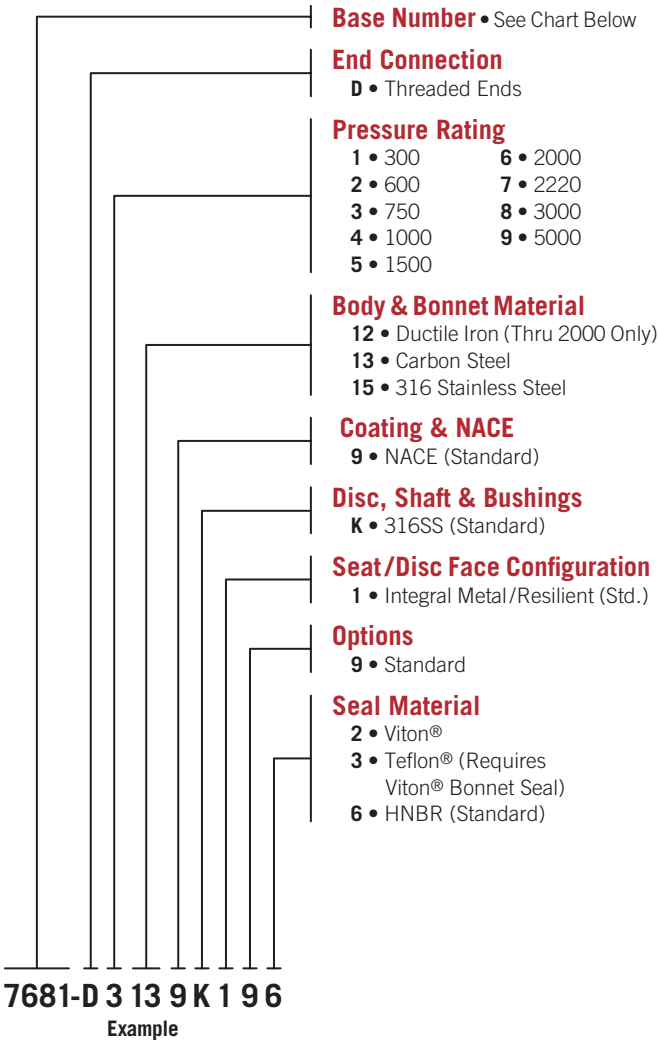

Dimensional Data (in., mm), 1"- 4"

Dim./Material (in., mm)		Size (in.)			
		1	2	3	4
A	All Materials	4.25	6.00	8.00	10.00
B	All Materials	3.58	4.36	5.80	7.11
Weight (lbs.)	Ductile Iron	5	10	23	46
	CS, SS	5	13	28	46
		Size (mm)			
A	All Materials	108.0	152.4	203.2	254.0
B	All Materials	90.1	110.8	147.3	180.6
Weight (kg)	Ductile Iron	2.3	4.5	10.4	20.9
	CS, SS	2.3	5.9	12.7	20.9

Consult factory for part numbers and dimensional data for parts not listed.

Assembly Base Numbers

Size (in.)			
1	2	3	4
7677	7679	7681	7682

KF Series 31B Check Valves



Threaded end connection swing style design with threaded bonnet.
Offered in 1" thru 4"
300 psi MOP

Features

- > Bronze body & bonnet
- > Acceptable for vertical "upflow" applications & suitable for pigging
- > NACE MR0175/ISO 15156

Part Number Codes

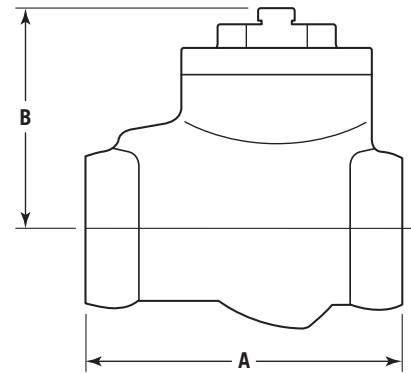
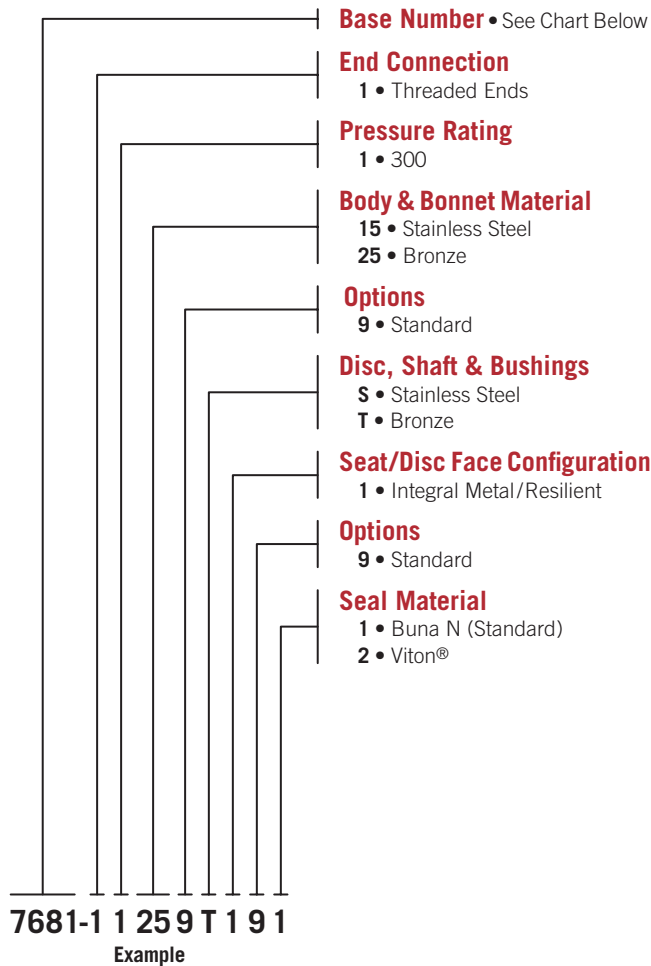

Dimensional Data (in., mm), 1"- 4"

Dimension (in., mm)	Size (in.)			
	1	2	3	4
A	3.75	5.25	7.25	9.25
B	2.00	3.00	4.38	5.25
Weight (lbs.)	4.5	8	17	37
Size (mm)				
A	95.2	133.3	184.1	235
B	50.8	76.2	111.1	133.3
Weight (kg)	2.0	3.6	7.7	16.8

Assembly Base Numbers

Size (in.)			
1	2	3	4
7677	7679	7681	7682



KF Valves

KF Series 35 Check Valves

Features

- > Std. trim includes 316 stainless steel disc, shaft & bushings
- > Unique opt. 316 stainless steel removable seat available
- > Installs in vertical "upflow" applications with no modification & suitable for pigging
- > NACE MR0175/ISO 15156

Flanged end RF & RTJ swing style integrally cast flange design.
Offered in 2 1/16" thru 7 1/16"
API 2000, 3000 & 5000
2" thru 16"
class 150, 300, 600, 900 & 1500

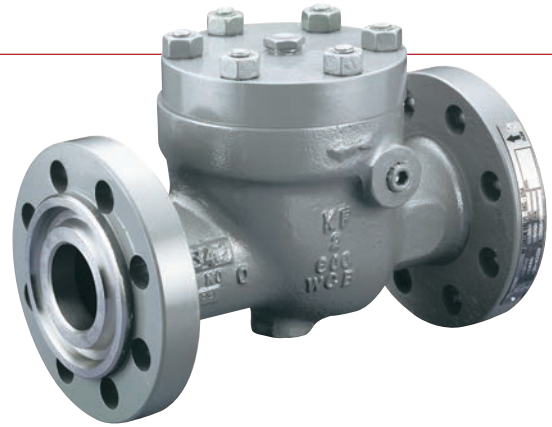

Dimensional Data (in., mm), 2 1/16"-7 1/16", API 2000, 3000 & 5000

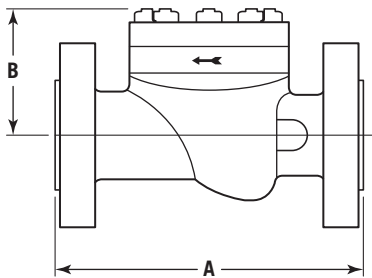

Dim./API (in., mm)	Size (in.)								
	2 1/16		3 1/8		4 1/16		7 1/16		
	in.	mm	in.	mm	in.	mm	in.	mm	
A	2000	11.63	295.3	14.13	358.8	17.13	435.0	22.13	562.0
	3000	14.63	371.5	15.13	384.2	18.13	460.4	24.13	612.8
	5000	14.63	371.5	18.63	473.1	21.63	549.3	28.00	711.2
B	2000	5.25	133.4	6.25	158.8	7.50	190.5	10.25	260.4
	3000	5.88	149.2	6.75	171.5	8.25	209.6	10.75	273.1
	5000	6.13	155.6	7.38	187.3	8.88	225.4	11.63	295.3
Ring Size	2000	R23	R23	R31	R31	R37	R37	R45	R45
	3000	R24	R24	R31	R31	R37	R37	R45	R45
	5000	R24	R24	R35	R35	R39	R39	R46	R46
Weight (lbs., kg)	2000	48	21.8	97	44.0	155	70.3	300	136.1
	3000	78	35.4	115	52.2	215	97.5	435	197.3
	5000	78	35.4	128	58.1	365	165.6	765	347.0

Dimensional Data (in., mm), 2"-16", Class 125, 300, 600, 900 & 1500

Dim./Class (in., mm)	Size (in.)																		
	2		3		4		6		8		10		12		14		16		
	in.	mm	in.	mm	in.	mm	in.	mm	in.	mm	in.	mm	in.	mm	in.	mm	in.	mm	
A	150	8.00	203.2	9.50	241.3	11.53	292.9	14.00	355.6	19.50	495.3	24.50	622.3	27.50	698.5	31.00	787.4	34.00	863.6
	300	10.50	266.7	12.50	317.5	14.00	355.6	17.50	444.5	21.00	533.4	24.50	622.3	28.00	711.2	33.00	838.2	34.00	863.6
	600RF	11.50	292.1	14.00	355.6	17.00	431.8	22.00	558.8	26.00	660.4	31.00	787.4	33.00	838.2	35.00	889.0	39.00	990.6
	600RTJ	11.63	295.3	14.13	358.8	17.13	435.0	22.13	562.0	26.13	663.6	31.13	790.6	33.13	841.5	35.13	892.2	39.13	993.8
	900RF	14.50	368.3	15.00	381.0	18.00	457.2	24.00	609.6	29.00	736.6	33.00	838.2	38.00	965.2	—	—	—	—
	900RTJ	14.63	371.5	15.13	384.2	18.13	460.4	24.13	612.8	29.13	739.8	33.13	841.4	38.13	968.4	—	—	—	—
	1500RF	14.50	368.3	18.50	469.9	21.50	546.1	27.75	704.9	32.75	831.9	39.00	990.6	44.50	1130.3	—	—	—	—
	1500RTJ	14.63	371.5	18.63	473.1	21.63	549.3	28.00	711.2	33.13	841.4	39.38	1000.1	45.13	1146.2	—	—	—	—
B	150	4.75	120.65	5.50	139.7	6.25	158.8	8.00	203.2	10.50	266.7	13.00	330.2	13.63	346.1	17.00	431.8	21.75	552.5
	300	4.75	120.65	5.50	139.7	6.50	165.1	8.88	225.4	11.75	298.5	13.00	330.2	14.50	368.3	18.25	463.6	21.75	552.5
	600	5.25	133.4	6.25	158.8	7.50	190.5	10.25	260.4	13.00	330.2	14.63	371.5	16.38	415.9	19.75	501.7	23.50	596.9
	900	5.25	133.4	6.75	171.5	8.25	209.6	10.75	273.1	13.75	349.3	15.50	393.7	17.25	438.2	—	—	—	—
	1500	5.88	149.2	7.38	187.3	8.88	225.4	11.63	295.3	15.50	393.7	18.25	463.6	20.50	520.7	—	—	—	—
Ring Size	600	R23	R23	R31	R31	R37	R37	R45	R45	R49	R49	R53	R53	R57	R57	R61	R61	R65	R65
	900	R24	R24	R31	R31	R37	R37	R45	R45	R49	R49	R53	R53	R57	R57	—	—	—	—
	1500	R24	R24	R35	R35	R39	R39	R46	R46	R50	R50	R54	R54	R58	R58	—	—	—	—
Weight (lbs., kg)	150	19	8.6	48	21.8	75	34.0	110	49.9	220	99.8	530	240.4	650	294.8	1150	521.6	2010	911.7
	300	26	11.8	65	29.5	101	45.8	185	83.9	370	167.8	530	240.4	900	408.2	1450	657.7	2010	911.7
	600	48	21.8	97	44.0	155	70.3	300	136.1	560	254.0	1020	462.7	1355	614.6	1975	895.8	2500	1134.0
	900	80	36.3	115	52.2	215	97.5	435	197.3	775	351.5	1250	567.0	1620	734.8	—	—	—	—
1500	118	53.5	128	58.1	365	165.6	765	347.0	1220	553.4	1560	707.6	2050	929.9	—	—	—	—	

KF Series 35 Check Valve Part Number Codes

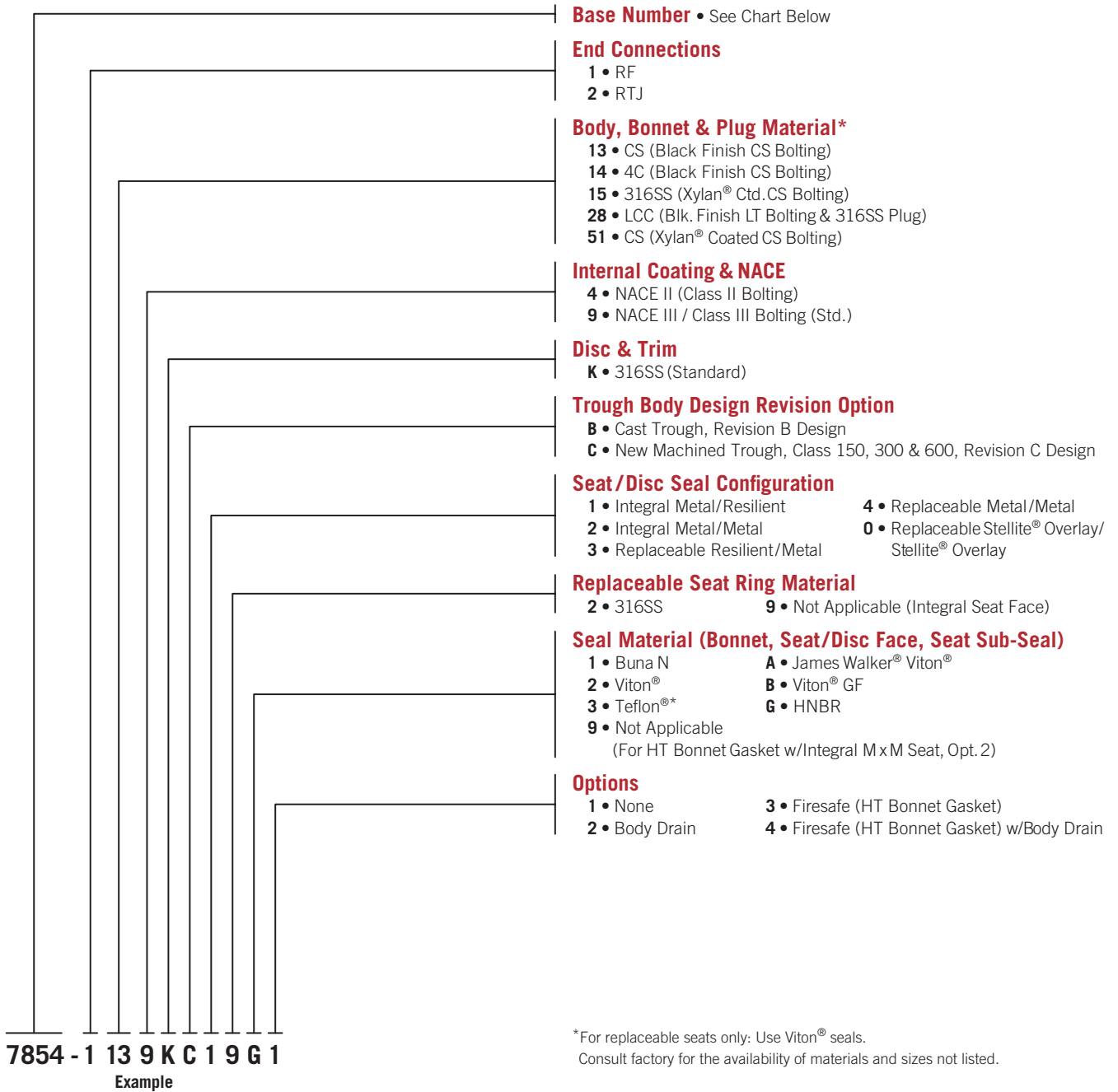

Assembly Base Numbers, 2"-24", Class 150, 300, 600, 900 & 1500 • 2 1/16"-7 1/16", API 2000, 3000 & 5000

Class	MOP	Size (in.)											
		2	3	4	6	8	10	12	14	16	18	20	24
150	285	7776-	7778-	7779-	7781-	7782-	7783-	7784-	7785-	7786-	7787-	7788-	7790-
300	740	7802-	7804-	7805-	7807-	7808-	7809-	7810-	7811-	7812-	7813-	—	7816-
600	1480	7854-	7856-	7857-	7859-	7860-	7861-	7862-	7863-	7864-	7865-	7866-	7868-
900	2220	7880-	7882-	7883-	7885-	7886-	7887-	7888-	—	—	—	7892-	—
1500	3705	7906-	7908-	7909-	7911-	7912-	7913-	7914-	—	—	—	—	—

API	Size (in.)			
	2 1/16	3 1/8	4 1/16	7 1/16
2000	7917-	7918-	7919-	7920-
3000	7926-	7927-	7928-	7929-
5000	7935-	7936-	7937-	7938-

KF Series 50 Piston Check Valves

Features

- Threaded piston seat that is easily removed & replaced while valve is in-line
- Smooth highly polished replaceable sleeve for easy maintenance & long-lasting performance
- Ideal for compressor & pulsating services
- Available with stellite® sealing surface & end connections in raised face or ring type joint
- Meets or exceeds ANSI B 16.34 requirements with flanges conforming to B 16.5.
Note: exception to lay length
- NACE MRO175/
ISO 15156 (optional)

The precisely metered check valve and orifice in the piston head combined with spring assisted closure controls piston descent to avoid seat slamming and promote smooth, quiet operation and positive backflow prevention with fluids or gasses.
Offered in 2" thru 8" • class 600 & 900

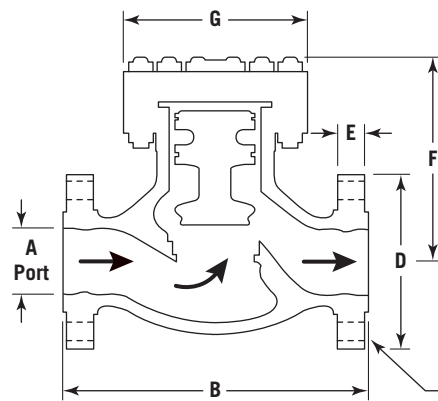
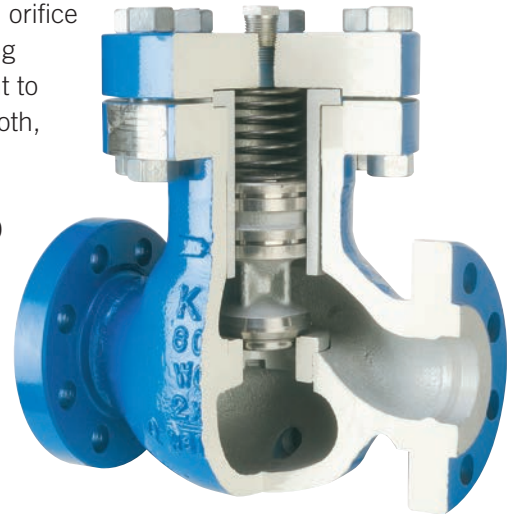

H • No. Holes
2"-4" • 8, 6"-8" • 12
J • Hole Dia.
K • Bolt Circle

Dimensional Data (in., mm), 2"-8", Class 600 & 900

Dim./Class (in., mm)	Size (in.)										
	2		3		4		6		8		
	in.	mm	in.	mm	in.	mm	in.	mm	in.	mm	
A	600-900	2.07	52.5	3.13	79.5	4.07	103.3	6.00	152.4	8.00	203.2
	600RF	11.00	279.4	14.75	374.7	18.50	469.9	20.75	527.1	24.00	609.6
B	900 RF	13.63	346.1	14.88	377.8	19.38	492.1	21.88	555.6	24.88	631.8
	600RTJ	11.13	282.6	14.88	377.8	18.63	473.1	20.88	530.2	24.13	612.8
	900RTJ	13.75	349.3	15.00	381.0	19.50	495.3	22.00	558.8	25.00	635.0
D	600	6.50	165.1	8.25	209.6	10.75	273.1	14.00	355.6	16.50	419.1
	900	8.50	215.9	9.50	241.3	11.50	292.1	15.00	381.0	18.50	469.9
E	600	1.25	31.8	1.50	38.1	1.75	44.5	2.13	54.0	2.44	61.9
	900	1.75	44.5	1.81	46.0	2.00	50.8	2.44	61.9	2.75	69.9
F	600	8.94	227.2	10.69	271.6	13.11	333.05	16.63	422.3	19.75	501.7
	900	9.56	242.0	11.63	299.5	13.88	352.5	17.63	447.7	20.25	514.4
G	600	7.50	190.5	9.88	250.8	11.00	279.4	14.50	368.3	18.00	437.2
	900	8.50	215.9	11.00	279.4	12.75	323.9	15.50	393.7	19.25	489.0
J	600	.75	19.1	.87	22.1	1.00	25.4	1.12	28.4	1.25	31.8
	900	1.01	25.6	1	25.4	1.25	31.8	1.25	31.8	1.50	38.1
K	600	5.00	127.0	6.63	168.3	8.50	215.9	11.50	292.1	13.75	349.3
	900	6.50	165.1	7.50	190.5	9.25	235.0	12.50	317.5	15.50	393.7
Ring Groove	600	R23	R23	R31	R31	R37	R37	R45	R45	R49	R49
RTJ Only	900	R24	R24	R31	R31	R37	R37	R45	R45	R49	R49
Weight (lbs., kg)	600	85	38.6	175	79.4	290	131.5	550	249.5	810	367.4
	900	135	61.2	235	106.6	335	152.0	790	358.3	1285	582.9

KF Series 50 Piston Check Valve Part Number Codes

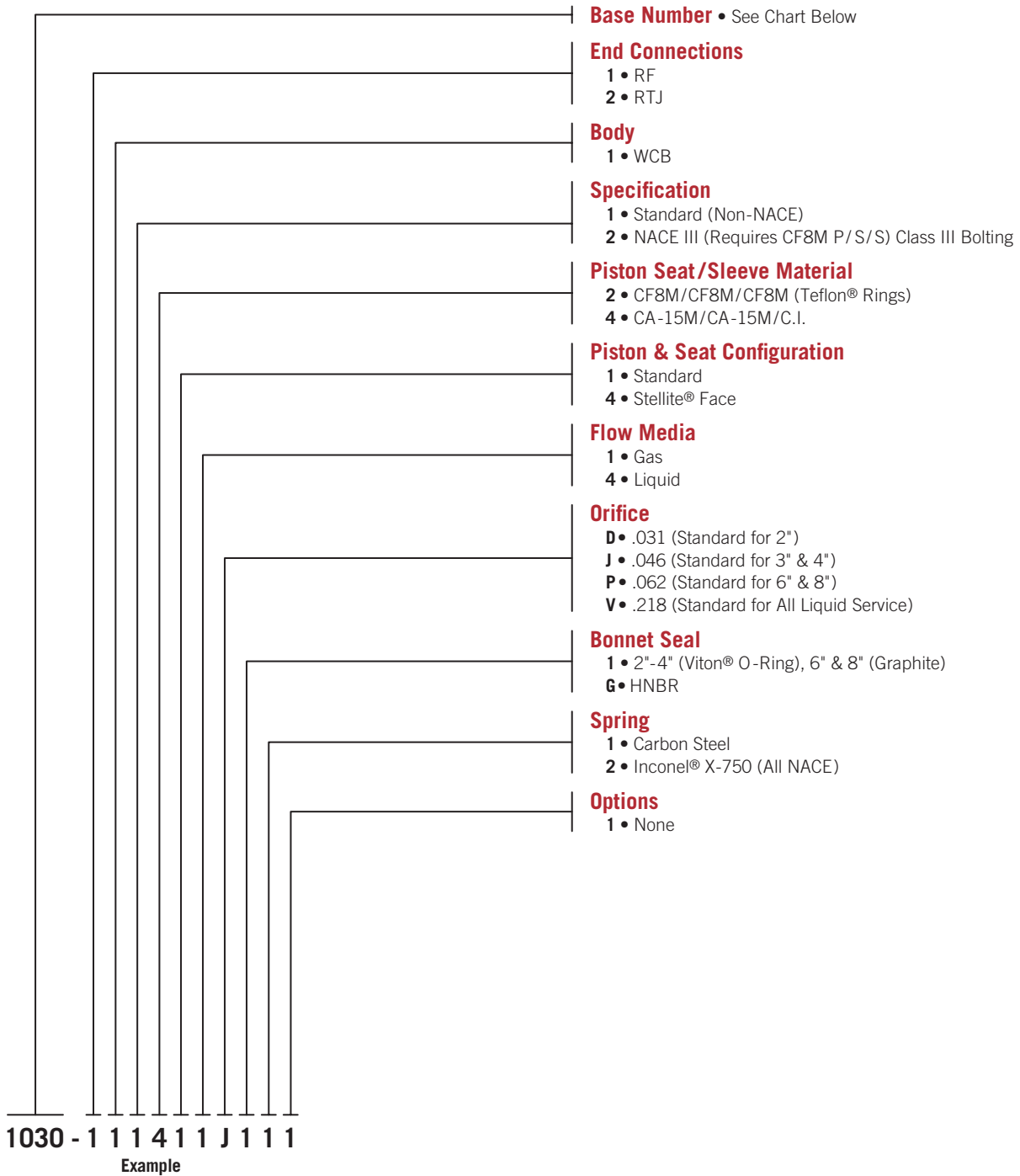

Assembly Base Numbers

Class	MOP	Size (in.)				
		2	3	4	6	8
300	740	1023-	1024-	1025-	1026-	1027-
600	1480	1029-	1030-	1031-	1032-	1033-
900	2220	1034-	1035-	1036-	1037-	1038-

KF Series 60 Ball Check Valves

Features

- > Replaceable resilient seat with a metal-to-metal back-up seal
- > Pulsating & low flow rate service causes minimal part wear & flow restriction is nominal
- > NACE MR0175/ISO 15156

Horizontal or vertical “upflow” installation. Gravity return eliminates need for ball return spring. Offered in 1" thru 2" 1000, 1500, 2000, 3000 & 5000 psi MOP

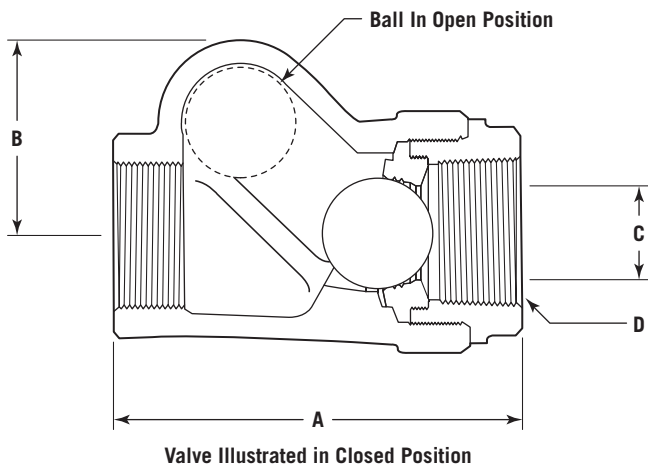

Dimensional Data (in., mm), 1"- 2"

Dimension (in., mm)	Size (in.)			
	1		2	
	in.	mm	in.	mm
A	4.38	111.1	6.50	165.1
B	1.94	49.2	3.13	79.4
C	.94	23.8	1.50	38.1
D	1-11.5 NPT	1-11.5 NPT	2-11.5 NPT	2-11.5 NPT
Wt. (lbs., kg)	3.50	1.6	14	6.4

Material Pressure Ratings

Pressure Rating	Material
1000 MOP	Ductile Iron
1500 MOP	Ductile Iron
2000 MOP	Ductile Iron, Cast Steel
3000 MOP	Cast Steel
5000 MOP	Cast Steel

Part Number Codes

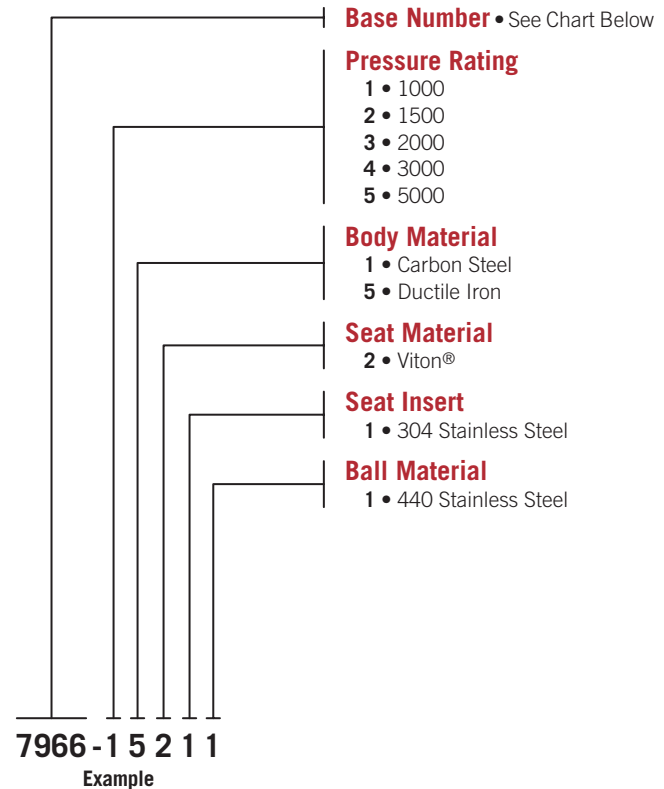

Flow Coefficient (C_v)

Size (in.)	
1	2
30	105

Assembly Base Numbers

Size (in.)	
1	2
7966-	7968-

Specifying KF Wafer Check Valves

The wafer check is installed between two flanges inside the bolt circle of the studs. Its unique design with a short face-to-face can tackle the toughest conditions. Compared to a conventional swing check valve, the wafer check valve is lighter and easier to install. The lighter weight makes the valve less expensive, especially in higher alloy materials. Wafer check valves reduce maintenance, installation, shipping cost and storage space. Unlike the conventional swing check valve, the wafer check valve requires only one set of studs and half the nuts. Expensive joints or special supports are not required.

KF wafer swing check valves perform in either horizontal or vertical upflow. They may be used in virtually any service except for pulsating reciprocating service. The round unobstructed port design makes the valve suitable for application in industries where dirty media are present. The round port decreases velocities, reduces pressure drop, damaging turbulence and debris collecting in the port area.

KF wafer swing check valves are designed to comply with API standard 594 and API 6D (long pattern). Materials of construction conform to ASTM standards and when requested, to NACE standard MR0175. KF wafer swing check valves are offered in sizes 2" and larger.

Trim Technology

Hardface Trim

The seating faces of the disc and the seat, either integral or removable, are weld overlaid with .06 inches minimum thickness of hardface to produce corrosion resistant hardfaced sealing surfaces. The disc can be furnished with either metal-to-metal or elastomer seals. Base metal can be either carbon or stainless steel. Removable seats with overlay are not available in wafer checks.

Stainless Overlay Trim

The seating surfaces of the disc and seat, either integral or removable, are weld overlaid with .06 inches minimum thickness of 316L stainless steel to produce corrosion resistant sealing surfaces. The disc can be furnished with either metal-to-metal or elastomer seals.

Metal-To-Metal Trim

Generally used for higher temperatures exceeding the capabilities of elastomers and plastics. The seating faces of the disc and seat, either integral or removable, are metal-to-metal. This configuration can be furnished in carbon steel, stainless steel or hardface trims. The leakage rate will not exceed that specified by API 598.

Removable/Replaceable Seat Ring

A removable seat ring can be furnished in any trim for 2" and larger bolted cover check valves. Unique patented seat provides easy replacement. Wafer check valves are also available with replaceable seat rings.

API Firesafe Bolted Bonnets

Many sizes and pressure classes of KF bolted bonnet full body style through conduit check valves are available as firesafe per API 6FD.

Applications

Series 10

- > Heating, ventilating & air conditioning
- > Irrigation
- > Blower
- > Pneumatic conveying
- > Suction & discharge pumping systems
- > Water injection & tank discharge
- > Chemical processing
- > Ship (on/off land, fire main, fuel oil)
- > Vapor recovery
- > Raw water
- > Condenser & cooling water
- > Vacuum
- > Refrigeration
- > Mobile tank
- > Refinery

Series 12

- > For applications where valve is normally closed and flow is relatively low, steady and not pulsating. Velocity not to exceed: liquid 15'/sec. • gasses 100'/sec.

Series 18, 20 & 22

- > Sewage handling
- > Dry material handling
- > Pulp & paper/body 317 stainless steel, internal spring, inconel®, ext. stainless steel
- > Sump pump
- > Mining
- > Blower discharge
- > Manifold systems
- > Slurry pumps
- > Oil & gas transmission
- > Recirculation systems
- > Booster stations
- > Chemical & food processing
- > Iron & steel mills
- > Irrigation & waste water
- > Municipal, ind. water & desalinization
- > Ethanol

Cross Reference for Series 10 Check Valve



Series 10 Equivalent

carbon steel body,
316 stainless steel trim,
buna n seal

ANSI 150

Apco: 912CRIR
digit #3 designates size
Gulf: MB 15-221SR
Marlin: 2A150CCNSR
digit #1 designates size
Mission: 15SMF
Muesco: 2.0-72-D-H-D-3H
digits #1 & 2 designates size
Keystone: FIG 810
Pro-Quip: 2BB11-1B
Technocheck: 5051
Valmatic: 8602-CCN-SSF
digits #3 & 4 designates size

ANSI 300

Apco: 932CRIR
digit #3 designates size
Gulf: MB 30-221SF
Marlin: 2A300-CCNSR
digit #1 designates size
Mission: 30SMF
Muesco: 2.0-74-D-H-D-3H
digits #1 & 2 designates size
Keystone: FIG 809
Pro-Quip: 4BB11-1B
Technocheck: 5053
Valmatic: 8502-CCN-SSR
digits #3 & 4 designates size

ANSI 600

Apco: 962CRIR
digit #3 designates size
Gulf: MB 60-221SR
Marlin: 2A600-CCNSR
digit #1 designates size
Mission: 60SMF
Pro-Quip: 6BB11-1B
Technocheck: 5056
Valmatic: 8302-CCN-SSR
digits #3 & 4 designates size

Series 10 Equivalent

316 stainless steel body,
316 stainless steel trim,
buna n seal

ANSI 150

Apco: 912GRIR
digit #3 designates size
Gulf: MB 15-641SR
Marlin: 2A150-SSNSR
digit #1 designates size
Mission: 15CMF
Muesco: 2.0-72-H-H-H-3H
digits #1 & 2 designates size
Keystone: FIG 810
Pro-Quip: 2DD11-1B
Technocheck: 5051-316
Valmatic: 8602-SSN-SSR
digits #3 & 4 designates size

ANSI 300

Apco: 932GRIR
digit #3 designates size
Gulf: MB 30-641SR
Marlin: 2A300-SSNSR
digit #1 designates size
Mission: 30CMP
Muesco: 2.0-74-H-H-H-3H
digits #1 & 2 designates size
Pro-Quip: 4DD11-1B
Technocheck: 5053-316
Valmatic: 8502-SSN-SSR
digits #3 & 4 designates size

ANSI 600

Apco: 962GRIR
digit #3 designates size
Gulf: MB 60-641SR
Marlin: 2A600-SSNSR
digit #1 designates size
Mission: 60CMP
Pro-Quip: 6DD11-1B
Technocheck: 5056-316
Valmatic: 8302-SSN-SSR
digits #3 & 4 designates size

Recommendations for Installed Position

Correct

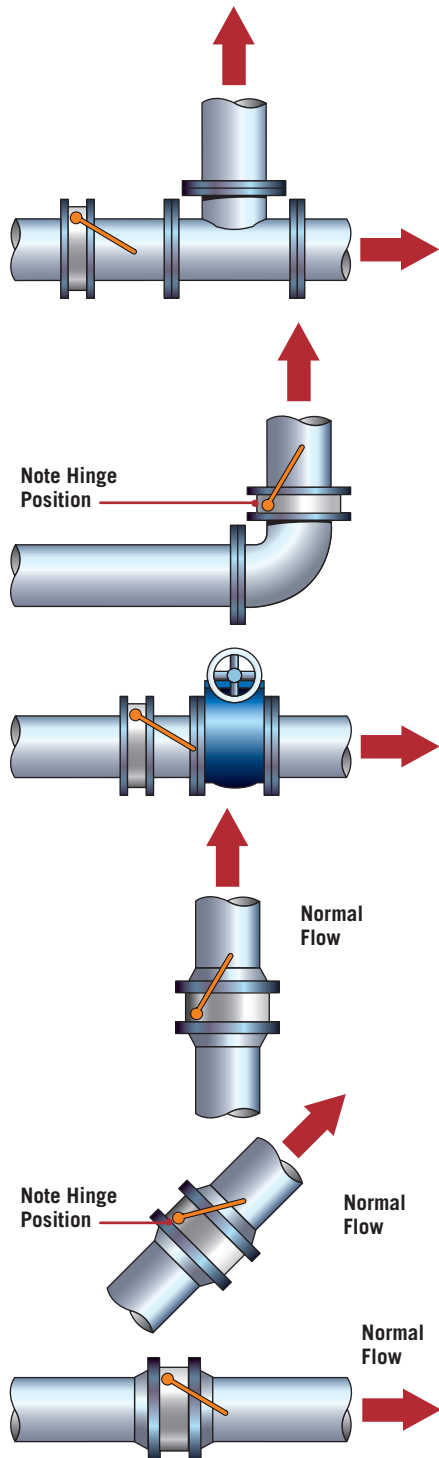

Incorrect

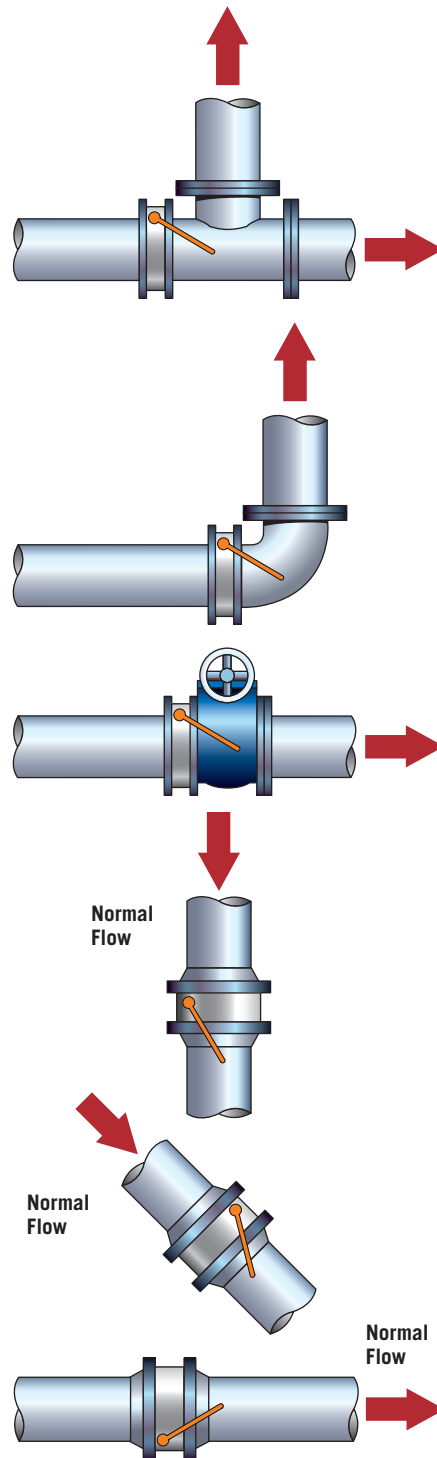

Position the check valve to promote smooth flow. Allow clearance for disc movement. Install the valve in horizontal or upward flow for proper valve closure.

Note: Swing check valves should not be used in reciprocating compressor or pulsating service. For such applications the KF series 50 piston check valve is recommended.

Engineering Data

Wafer Check Temperature & Working Pressure by Classes

A216 Grade WCB or A105 Carbon Steel • ANSI B16.34

Temp (°F)	Working Pressure By Classes (psig)					
	150	300	600	900	1500	2500
-20 to 100	285	740	1480	2220	3705	6170
200	260	675	1350	2025	3375	5625
300	230	655	1315	1970	3280	5470
400	200	635	1270	1900	3170	5280
500	170	600	1200	1795	2995	4990
600	140	550	1095	1640	2735	4560
650	125	535	1075	1610	2685	4475
700	110	535	1065	1600	2665	4440
750	95	505	1010	1510	2520	4200
800	80	410	825	1235	2060	3430
850	65	270	535	805	1340	2230
900	50	170	345	515	860	1430
950	35	105	205	310	515	860
1000	20	50	105	155	260	430

A351 Grade CF8M 316 Stainless Steel • ANSI B16.34

Temp (°F)	Working Pressure By Classes (psig)					
	150	300	600	900	1500	2500
-20 to 100	275	720	1440	2160	3600	6000
200	240	620	1240	1860	3095	5160
300	215	560	1120	1680	2795	4660
400	195	515	1030	1540	2570	4280
500	170	480	955	1435	2390	3980
600	140	450	905	1355	2255	3760
650	125	445	890	1330	2220	3700
700	110	430	865	1295	2160	3600
750	95	425	845	1270	2110	3520
800	80	415	830	1245	2075	3460
850	65	405	810	1215	2030	3320
900	50	395	790	1180	1970	3280
950	35	385	775	1160	1930	3220
1000	20	365	725	1090	1820	3030
1050	—	360	720	1080	1800	3000
1100	—	325	645	965	1610	2685
1150	—	275	550	825	1370	2285
1200	—	205	410	620	1030	1715
1250	—	180	365	545	910	1515
1300	—	140	275	410	685	1145
1350	—	105	205	310	515	860
1400	—	75	150	225	380	630
1450	—	60	115	175	290	485
1500	—	40	85	125	205	345

A352 Grade LCB Low Temp Carbon Steel • ANSI B16.34

Temp (°F)	Working Pressure By Classes (psig)					
	150	300	600	900	1500	2500
-20 to 100	265	695	1390	2085	3470	5785
200	250	655	1315	1970	3280	5470
300	230	640	1275	1915	3190	5315
400	200	620	1235	1850	3085	5145
500	170	585	1165	1745	2910	4850
600	140	535	1065	1600	2665	4440
650	125	525	1045	1570	2615	4355

A126 Class B Cast Iron • ANSI B16.1

Temp (°F)	Working Pressure By Classes (psig)					
	125 (NPS)			250 (NPS)		
	1-12	14-24	30-48	1-12	14-24	30-48
-20 to 150	200	150	150	500	300	300
200	190	135	115	460	280	250
225	180	130	100	440	270	225
250	175	125	85	415	260	200
275	170	120	65	395	250	175
300	165	110	50	375	240	150
325	155	105	—	355	230	125
353	150	100	—	335	220	100
375	145	—	—	315	210	—
406	140	—	—	290	200	—
425	130	—	—	270	—	—
450	125	—	—	250	—	—

A352 Grade LCC Low Temp CS • ANSI B16.34 (650°F Max.)

A217 Grade Martensitic SS CA-15 • ANSI B16.34 Annex F

Temp (°F)	Working Pressure By Classes (psig)					
	150	300	600	900	1500	2500
-20 to 100	290	750	1500	2250	3750	6250
200	260	750	1500	2250	3750	6250
300	230	730	1455	2185	3640	6070
400	200	705	1410	2115	3530	5880
500	170	665	1330	1995	3325	5540
600	140	605	1210	1815	3025	5040
650	125	590	1175	1765	2940	4905
700	110	570	1135	1705	2840	4730

Flow Coefficients (C_v)

Series	Size (in.)													
	2	3	4	5	6	8	10	12	14	16	18	20	24	
10, 19, 20, 22	95	156	366	430	710	1280	2350	3850	4260	7000	9550	13,000	25,000	
12	75	124	300	405	675	1000	1950	3050	—	—	—	—	—	
35	120	250	450	—	1320	2816	5200	8500	10,250	13,500	17,250	21,500	31,500	



KF Valves

Engineering Data

Wafer Check Temperature & Working Pressure by Classes

B148 Alloy 952 Aluminum Bronze • ANSI B16.31

Temp (°F)	Working Pressure By Classes (psig)					
	150	300	600	900	1500	2500
-20 to 100	195	515	1030	1545	2575	4290
150	165	430	855	1285	2140	3570
200	155	400	800	1205	2005	3340
250	145	385	770	1150	1920	3200
300	140	370	740	1110	1850	3085
350	140	365	735	1100	1835	3060
400	140	365	725	1090	1820	3030
450	140	360	725	1085	1805	3010
500	140	360	720	1080	1800	3000

A395 Ductile Iron • ANSI B16.42

Temp (°F)	Working Pressure By Classes (psig)	
	150	300
-20 to 100	250	640
200	235	600
300	215	565
400	200	525
500	170	495
600	140	465
650	125	450

Sealing Member Materials*

Material	Temp Range (°F)	Material	Temp Range (°F)
Aflas®	+32 to 450	Low Temp Buna N	-50 to 250
Buna N	-20 to 250	Peroxide Cured Buna N (90 Duro)	-20 to 275
EPDM	-50 to 450	Teflon®	-50 to 425
HNBR	-50 to 350	Viton®	-15 to 400

*Depends on media.

Performance Loss Curves • Wafer Check Valves Only

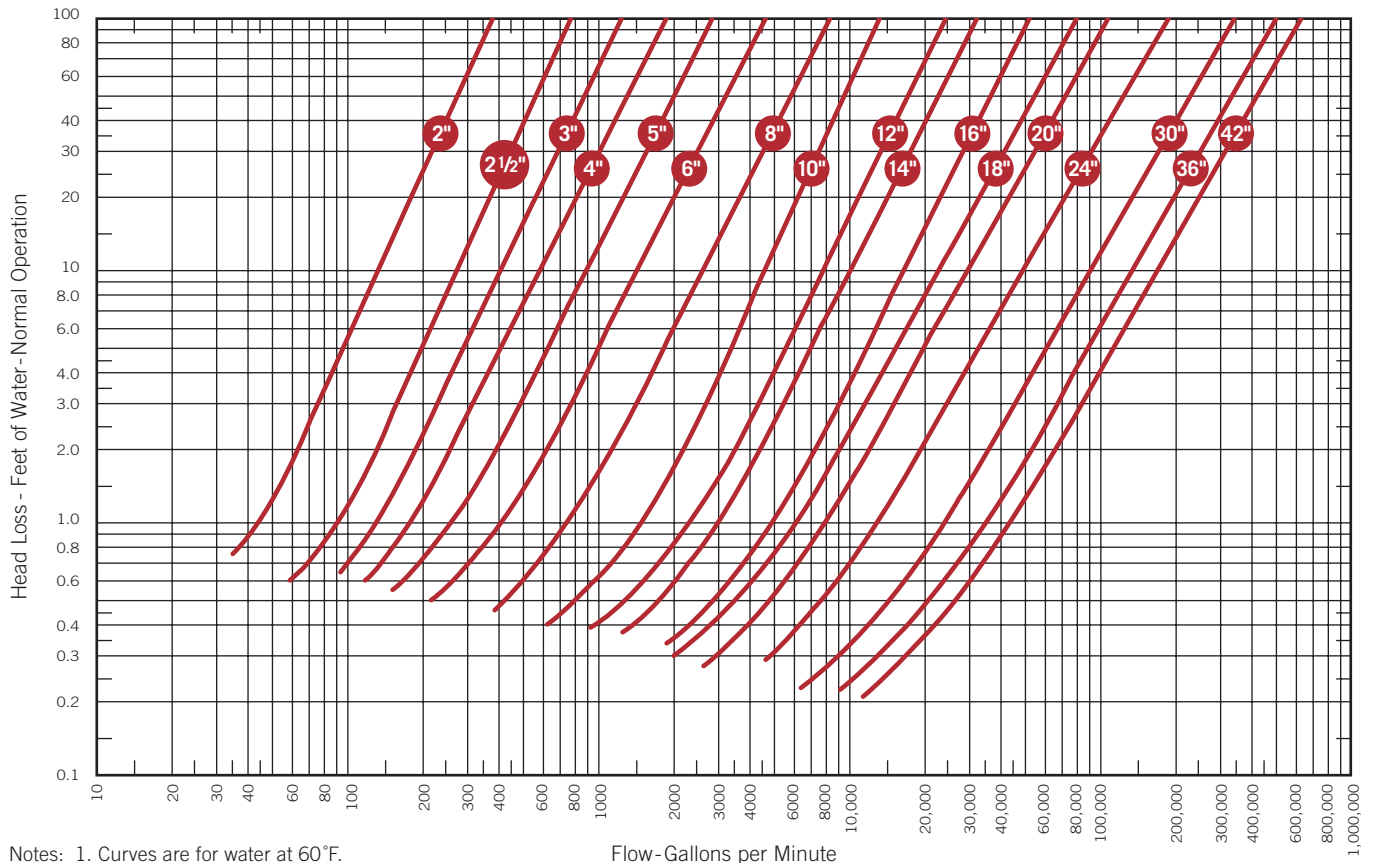

- Notes:
1. Curves are for water at 60°F.
 2. Feet of water x .4335 = psi drop.
 3. Use curves for estimating purposes only, performance is based upon ideal inlet and outlet conditions with no springs or weights. Since spring and/or weight requirements for acceptable operation may vary from system to system, their effects must be added.



CIRCOR Energy is a global manufacturer of highly engineered valves, fittings, pipeline and associated products for general, critical and severe service applications in the Oil & Gas, Power Generation and Process Industry markets. CIRCOR Energy continuously develops precision technologies to improve our customers' ability to control the flow of the world's natural resources.

Continuously Improving Flow Control. Worldwide.

Asia | Europe | Middle East | North America | South America



KF Valves

sales@circorenergy.com

www.circorenergy.com

©2015 CIRCOR Energy. All rights reserved.
KF-CHECKS-JULY-2015-2UP-CME

KF Valves reserves the right to change designs, materials, or specifications without notice or without obligation to furnish or install such changes on products previously or subsequently sold.

Inconel® is a registered trademark of Special Metals Corporation, USA • Stellite® is a registered trademark of Kennametal Stellite, Inc. • Viton® is a registered trademark of DuPont Dow Elastomers. • James Walker® is a registered trademark of James Walker. • Teflon® is a registered trademark of DuPont. • Aflas® is a registered trademark of Asahi Glass. • Xylan® is a registered trademark of Whitford. • Enduro-Bond™ is a trademark of Energy & Environmental Services.